

DERALE

PERFORMANCE

2009



The Leader in Performance Cooling



The Leader In Performance Cooling

Why "DeraLe Performance"?

As we look back over the last 30 years at the DeraLe product line, one thing stands out above all others.....change. We pride ourselves on positive and productive change and it's a major reason that our future is brighter than ever.

In the early 1980's the company focused primarily on oil coolers, fittingly our name reflected our products; "DeraLe Oil Coolers". By the end of the decade the product line had expanded further into the cooling products arena having added electric fans, flex fans, fan clutches and transmission cooling pans. This growth required a more appropriate label to match our progress, and we became "DeraLe Cooling Products". Once again as our long term goals and product line expands past the limitations of the current name, it is appropriate to change the name once again to "DeraLe Performance".

Regardless of our name, the one thing that remains unchanged is the quality, service, and relationships we have built over the years. As you can see in this new catalog and in the very near future, we are no longer your typical cooling products company. We hope that you are as excited about these changes as we are.

Who is "Dyno-Cool"?

In the new global economy many competitors now source everything from individual components to entire assemblies overseas, DeraLe's predominantly "Made in the USA" product line has had an increasingly difficult time competing in certain market segments, namely the value priced market. This segment continues to grow, and with people's income being strained by the rising cost of transportation, energy, food, and housing, this trend is likely to continue.

Dyno-Cool by DeraLe allows the company the flexibility not only to remain in the value segment market, but our expertise allows us to build relationships with overseas cooling product manufacturers interested in supplying high quality products. The companies that supply our Dyno-Cool line are leaders as well, and OE suppliers to companies such as Ferrari, Toyota, Nissan and others. We back these outsourced products as we do our own. There are many suppliers of cooling products overseas selling directly to the U.S., but few who are in the cooling business. There is a difference.

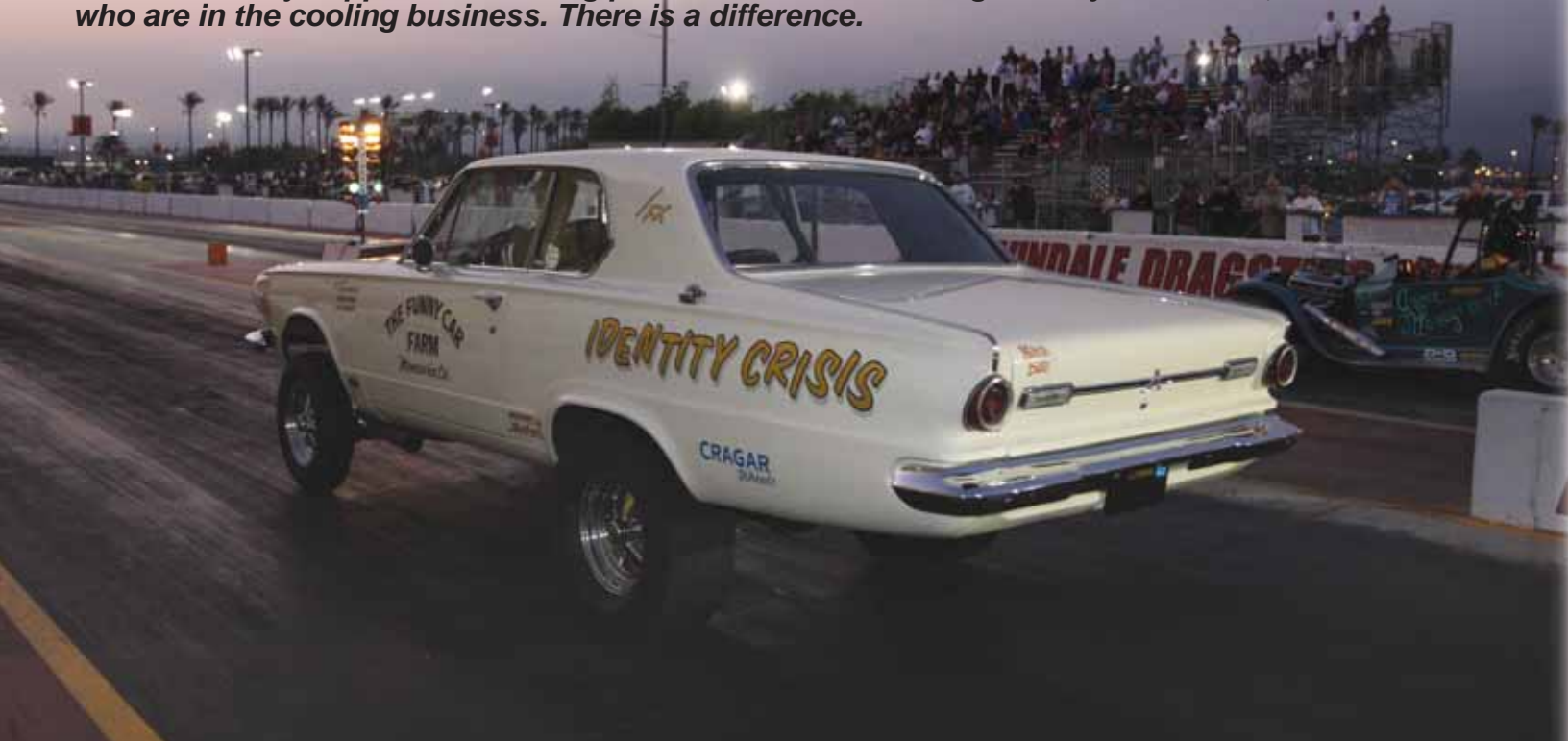

TABLE OF CONTENTS

Electric Fans

High Output Dual RAD Fans.....	2-3
High Output Single RAD Fans.....	4-5
Tornado Fans	6
Dual Tornado Fans with Brackets.....	7
Tornado Fan Mounting Brackets.....	7
Dyno-Cool Curved Blade Fans.....	8
Dyno-Cool Straight Blade Fans.....	9
Dyno-Cool Electra-Flex Fans.....	10

Electric Fan Accessories

Installation Kits.....	11
Mounting Brackets	11
Relay Wire Harness Kits	11

Electric Fan Controllers

Adjustable Thermostats.....	12
Single Stage Thermostats	13

Transmission Pans & Accessories

Transmission Pan Coolers	14-15
Transmission Pan Filter Extensions.....	15
Drain Plug Kits.....	15

Direct Fit Jeep Kits

Radiator Electric Fan Kit.....	16
Automatic Transmission Cooler Kit.....	17

Remote Oil & Transmission Coolers

Hyper-Cool	18
Atomic-Cool	19
Electra-Cool	20
Econo-Cool	21
Dyno-Cool Remote Coolers.....	21
Remote Cooler Accessories.....	22
In-line Fluid Thermostats.....	22

Fluid Cooler Accessories

Cooler Installation Kits	23
Oil Temperature Gauges	23
Replacement Hose	23

Stacked Plate Coolers

Cooler Kits	24
Transmission Cooler Kits	25
Cooler Fittings & Mounting Brackets	25

Transmission Coolers

Series 9000 Plate and Fin Cooler Kits	26
Series 8000 Plate and Fin Cooler Kits	27
Series 7000 Tube and Fin Cooler Kits	28
Dyno-Cool Aluminum Tube and Fin Cooler Kits	29
Series 7000 AN Tube and Fin Cooler Kits	30
Dyno-Cool Aluminum SAE Tube and Fin Cooler Kits	30

Cooler Cores

Series 7000 AN Tube and Fin Cooler Cores..	31
--	----

Frame Rail Coolers

Transmission Cooler Kits	32
Fluid Coolers.....	32

Heat Sink Coolers

Transmission Cooler Kits	33
Fluid Coolers.....	33

Transmission Cooler Accessories

Radiator Adapter Fittings	34
---------------------------------	----

Power Steering Cooler Kits

Tube & Fin Cooler Kits	35
Dyno-Cool Aluminum Tube & Fin Cooler Kits	35

Engine Oil Cooler Kits

Engine Adapter Quick Reference Guide	36
Engine Sandwich Adapter Kits	37
Engine Spin-on Adapters Kits	38

Engine Oil Filter Relocation Kits

Single Filter Mount	39
Dual Filter Mount	39

Engine Sandwich Adapter Kits

Engine Sandwich Adapter Kits	40
------------------------------------	----

Engine Spin-on Adapter Kits

Engine Spin-on Adapter Kits.....	41
----------------------------------	----

Remote Filter Mounts

Standard Series	42
Premium Series	43

Fluid Control Thermostats

Standard Series	44
Premium Series	44

Remote Filter Kits

Transmission Kits.....	45
Fuel Filter Kits.....	45

Fittings & Accessories

Fittings & Accessories.....	46
-----------------------------	----

Belt Driven Fan Spacers

Belt Driven Fan Spacers	47
-------------------------------	----

Belt Driven Fans

Heavy Duty Flex Fans	48
High Performance Flex Fans	49-50
Fan Clutch Fans.....	50
Rigid Race Fans.....	51

Fan Clutches

Fan Clutches.....	52
-------------------	----

High Output Dual RAD Fan

- Designed for primary cooling
- Powdercoated metal shroud with stator flow directors
- High Output 265 watt motors
- Ultra-quiet patented skewed blade design
- Multiple mounting options
- Puller (engine side) applications only
- Available in two hardware kit options



Part #
16927

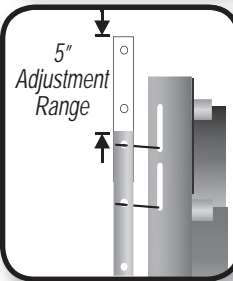
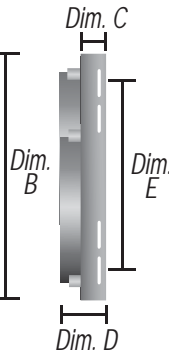
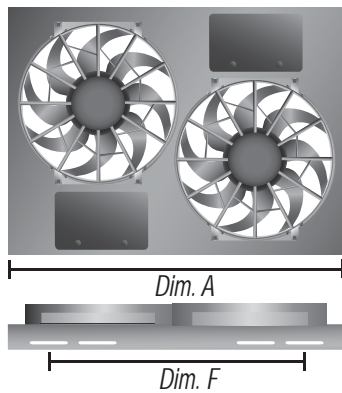

NEW



WIRING RECOMMENDATIONS:

Fan Kit - Includes mounting kit with two high amperage relay harnesses
Thermostat Kit - Includes installation kit with two thermostats and relay harnesses
Fan 1 - 180°F turn on temperature with push-in or screw-in probe
Fan 2 - 190°F turn on temperature with screw-in probe only
 See Pages 12 & 13 for alternative thermostat options

Fan Kit Part No.	Fan & Thermostat Kit Part No.	CFM*	Amp Draw (Fan 1 / 2)	Dim. A (Width)	Dim. B (Height)	Dim. C (Depth)	Dim. D (Overall Depth)	Dim. E (Mounting)	Dim. F (Mounting)
16927	16027	4000	24.8 / 24.8	26"	18"	2"	3 3/4"	13 1/4"	21 1/4"

* CFM tested at zero static pressure.



ELECTRIC FANS

High Output Dual RAD Fans

- Designed for primary cooling
- Injection molded shroud with stator flow directors
- High Output 265 watt motors
*No. 16812 excluded
- Ultra-quiet patented skewed blade design
- Multiple mounting options
- Puller (engine side) applications only
- Available in two hardware kit options



Part #
16928



Part #
16934



WIRING RECOMMENDATIONS:

Fan Kit - Includes mounting kit with two high amperage relay harnesses

Fans require two separate turn-on sources

Thermostat Kit - Includes installation kit with two thermostats and relay harnesses

Fan 1 - 180°F turn on temperature with push-in or screw-in probe

Fan 2 - 190°F turn on temperature with screw-in probe only

See Pages 12 & 13 for alternative thermostat options

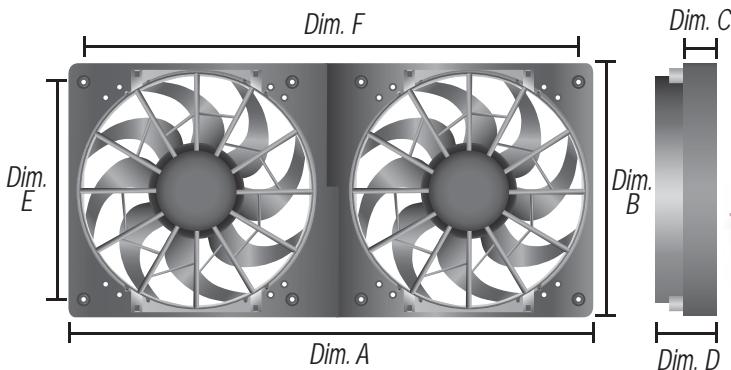

Fan Kit Part No.	Fan & Thermostat Kit Part No.	CFM*	Amp Draw (Fan 1 / 2)	Dim. A (Width)	Dim. B (Height)	Dim. C (Depth)	Dim. D (Overall Depth)	Dim. E (Mounting)	Dim. F (Mounting)
16812	-----	1360	4.8 / 4.8	24 3/4"	11 1/2"	1 1/4"	3"	10"	22 1/2"
16928	16028	4000	24.8 / 24.8	28 5/8"	13 7/8"	1 1/2"	3 1/2"	11 3/8"	25 5/8"
16934	16034	4000	24.8 / 24.8	31 3/8"	15 3/4"	1 3/8"	3 1/4"	12 7/8"	28 7/8"

* CFM tested at zero static pressure.

High Output Single RAD Fans

- Mounts as a Pusher or Puller without flipping blade or switching motor leads
- State-of-the-art symmetrical design
- High Output 265 watt 2 speed motor
- Ultra-quiet patented skewed blade design
- Patented ratchet mounting system
- Multiple mounting options



Part# 16217

Part# 16214

Part# 16212

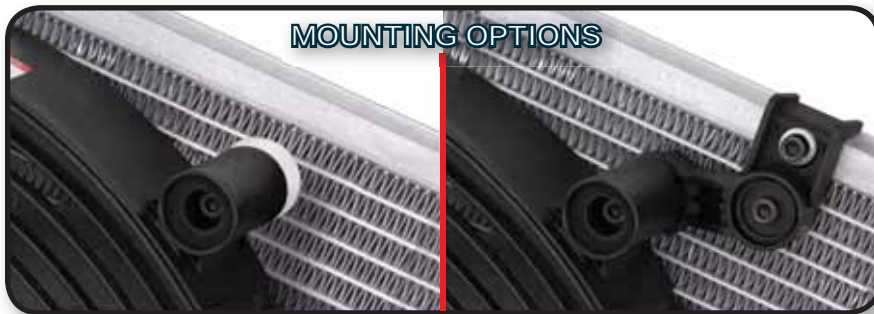

MOUNTING OPTIONS



DUAL MOUNTING BRACKET KIT

WIRING RECOMMENDATIONS:

For two speed operations fans require two separate turn-on sources
See Pages 12 & 13 for thermostat options

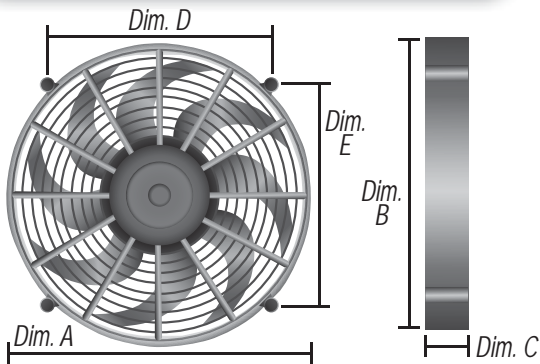

HARDWARE KIT



DUAL MOUNT BRACKET KIT

Part# 16200

Easily combines any two size fans shown for dual applications.

Part No.	Fan Size	CFM* High / Low	Amp Draw High / Low	Dim. A (Width)	Dim. B (Height)	Dim. C (Depth)	Dim. D (Mounting)	Dim. E (Mounting)
16212	12"	1450 / 1000	21 / 15	12 3/4"	12 3/4"	2 5/8"	8 1/4"	11 5/8"
16214	14"	2100 / 1500	22 / 16.2	14 1/2"	14 1/2"	2 5/8"	8 3/4"	13 1/4"
16217	17"	2400 / 1800	23.5 / 17.4	16 7/8"	16 7/8"	2 5/8"	8 7/8"	15 5/8"
16200	Dual Mount Bracket Kit							

* CFM tested at zero static pressure.

ELECTRIC FANS

High Output Single RAD Fans

- Designed for primary cooling
- High Output two speed motor
- Ultra-quiet patented skewed blade design
- Powdercoated metal fan shroud
- Puller (Engine Side) applications only



- Perfect for harsh off road environments
- High Output motor
- Dust & Water proof Motor design
- IP68 Certified
- Puller applications only



Part No.

16919



HARDWARE KIT

Part No.

16918



HARDWARE KIT

WIRING RECOMMENDATIONS:

Includes high amperage relay wire harness
See Pages 12 & 13 for thermostat options



WIRING RECOMMENDATIONS:

Includes high amperage relay wire harness
For two speed operations fan requires two separate turn-on sources
See Pages 12 & 13 for thermostat options

- Injection molded fan housing with stator flow directors
- High Output 265 watt motor
- Ultra-quiet patented skewed blade design
- Pusher applications only



Can be used in Puller applications when custom shroud is used. Replacement fan for Derale numbers: 16926, 16927, 16928 & 16934

Part No.

16925



Part #
16926

Part No.

16926



HARDWARE KIT

WIRING RECOMMENDATIONS:

Includes high amperage relay wire harness
See Pages 12 & 13 for thermostat options



HARDWARE KIT

WIRING RECOMMENDATIONS:

Includes high amperage relay wire harness
See Pages 12 & 13 for thermostat options

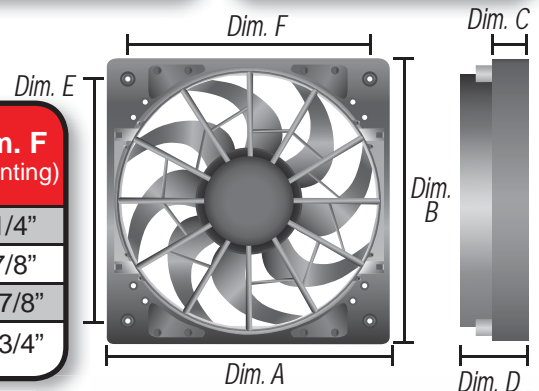

Part No.	CFM*	Amp Draw	Dim. A (Width)	Dim. B (Height)	Dim. C (Depth)	Dim. D (Overall Depth)	Dim. E (Mounting)	Dim. F (Mounting)
16918	1650	12.0	12"	12"	1 5/8"	3 1/2"	9 1/4"	9 1/4"
16925	2150	23.4	12 1/4"	12 5/8"	1 1/2"	3 1/8"	10 5/8"	7 7/8"
16926	2200	23.4	15 3/4"	15 3/4"	1 7/8"	3 1/8"	12 7/8"	12 7/8"
16919+	2400 / 1800	23.5 / 17.4	19 1/2"	18"	1 5/8"	3 5/8"	8 7/8"	15 3/4"

+ Two speed motor .

* CFM tested at zero static pressure.

ELECTRIC FANS

Tornado Fans

- Reliable, efficient, high torque motors
- Ultra-quiet patented skewed blade design
- Offered in 9 sizes to fit multiple applications
- Available in two hardware kit options, Manual switch or Thermostatically controlled



WIRING RECOMMENDATIONS:
Fan Kit - Includes mounting kit with lighted toggle switch & wiring
Thermostat Kit - Includes installation kit with 180°F thermostat
 See Pages 12 & 13 for thermostat options

+ Note: 4" & 5" fans are designed as puller fans only. (Not reversible)

Note: Fan & thermostat kits include both push-in radiator fin probe & screw in water jacket probe.

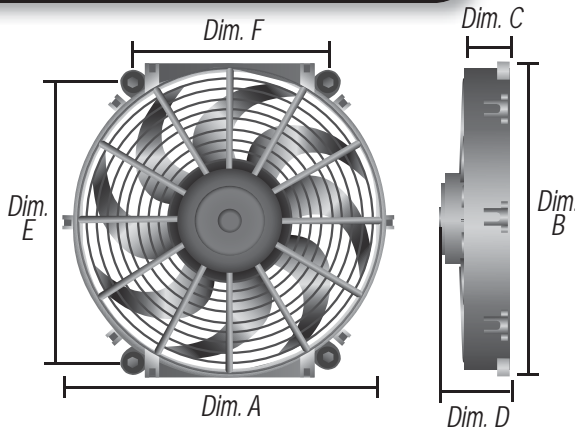

Relay wire harness included in Part No. 16016 only.

Fan Kit Part No.	Fan & Thermostat Kit Part No.	Fan Size	CFM*	Amp Draw	Dim. A (Width)	Dim. B (Height)	Dim. C (Depth)	Dim. D (Overall Depth)	Dim. E (Mounting)	Dim. F (Mounting)
16504	16004	4"	125	1.9	4 1/4"	4 1/4"	1 1/4"	2 3/8"	3 1/4"	3 1/4"
16505	16005	5"	315	3.6	5 5/8"	6 1/4"	1 1/4"	2 1/4"	4 1/4" Three Hole mount	
16507	16007	7"	400	4.8	7 1/4"	7 1/8"	1 3/8"	2 3/8"	5 3/8"	5 3/8"
16508	16008	8"	500	4.8	8 1/4"	8"	1 3/8"	2 3/8"	6"	6"
16509	16009	9"	570	5.4	9 5/8"	9 1/2"	1 1/4"	2 1/2"	8 7/8"	5"
16510	16010	10"	650	5.3	11 1/4"	10 5/8"	1 1/2"	2 1/2"	9 5/8"	6 7/8"
16512	16012	12"	880	8.8	13"	12 1/8"	1 1/2"	2 1/2"	11 1/8"	5 7/8"
16514	16014	14"	1350	10.5	14 1/2"	14"	1 3/4"	3 1/4"	12 1/4"	9"
16516	16016	16"	2175	18.4	16 3/4"	15 1/2"	1 3/4"	3 7/8"	13 3/4"	9 3/4"

* CFM tested at zero static pressure.

ELECTRIC FANS

DUAL Tornado Fans with Brackets

- Available with dual 12" or 14" Tornado Fans
- Sturdy metal bracket system
- Black powdercoated finish

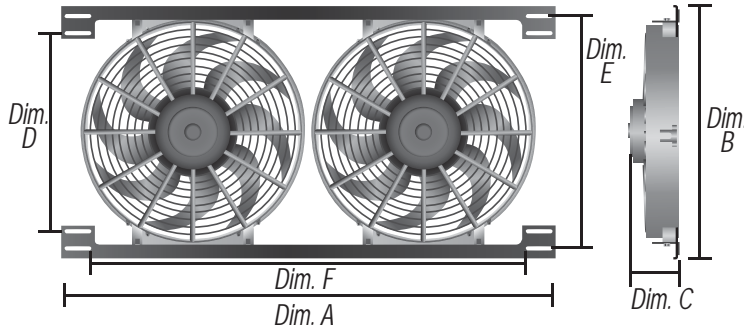

REVERSIBLE



WIRING RECOMMENDATIONS:
See Pages 12 & 13 for thermostat options

Part No.	Fan Size	CFM* (Fan 1 / 2)	Amp Draw (Fan 1 / 2)	Dim. A (Width)	Dim. B (Height)	Dim. C (Overall Depth)	Dim. D (Mounting)	Dim. E (Mounting)	Dim. F (Mounting)
16824	Dual 12"	880 / 880	8.8 / 8.8	27 3/4"	14"	1 5/8"	10 1/8"	13 5/8"	23 1/2"
16834	Dual 14"	1350 / 1350	10.5 / 10.5	31 3/4"	15 5/8"	1 3/4"	12 1/8"	14 5/8"	27 1/2"

* CFM tested at zero static pressure.

Tornado Fan Mounting Brackets

- Fits 10", 12", 14" and 16" Tornado Fans

- Adjustable universal mounting
- Perfect for most applications

SINGLE FAN MOUNTING BRACKETS

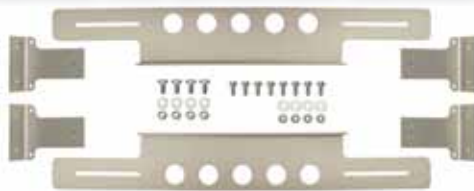

Part No.	Description
16700	Single Fan Mounting Brackets

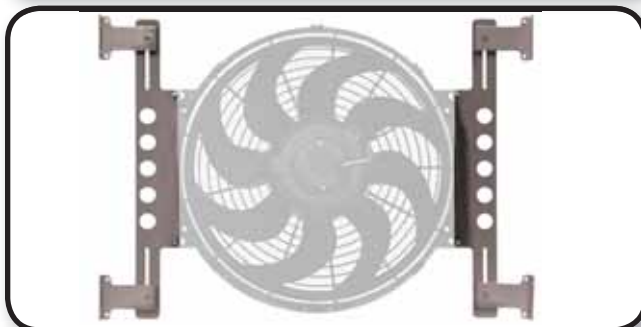

DUAL FAN MOUNTING BRACKETS



Part No.	Description
16701	Dual Fan Mounting Brackets

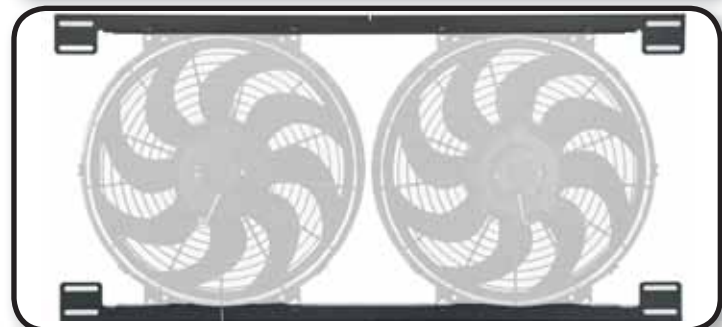

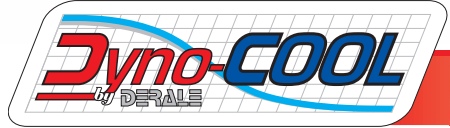

Curved Blade Fans

- Efficient curved blade design
- Offered in 5 sizes to fit multiple applications
- 16" Fan is offered as an Ultra Low Profile design

- Available in two hardware kit options, Manual switch or Thermostatically controlled
- Fan & thermostat kit includes two probe options



Note: Fan & Thermostat kits include both push-in radiator fin probe & screw in water jacket probe.

WIRING RECOMMENDATIONS:
Fan Kit - Includes mounting kit
Thermostat Kit - Includes installation kit with 180°F thermostat
 See Pages 12 & 13 for thermostat options

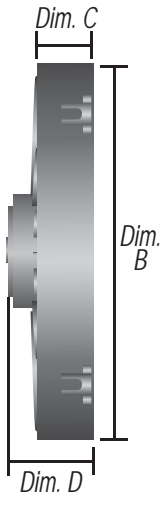
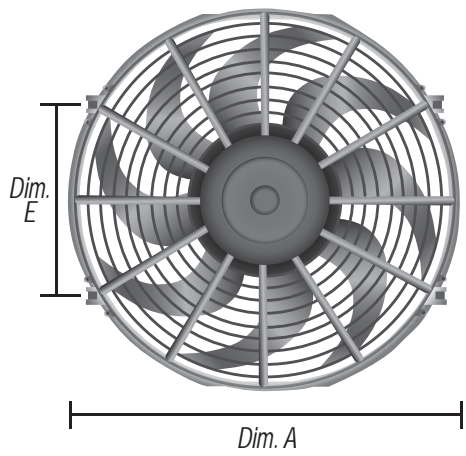

Relay wire harness included in Part No. 18316 only.

Fan Kit Part No.	Fan & Thermostat Kit Part No.	Fan Size	CFM*	Amp Draw	Dim. A (Width)	Dim. B (Height)	Dim. C (Depth)	Dim. D (Overall Depth)	Dim. E (Mounting)
18909	18309	9"	515	5.1	10 1/2"	9 3/4"	1 1/8"	2 1/4"	4 9/16"
18910	18310	10"	590	5.3	11 1/2"	10 3/4"	1 1/2"	2 3/8"	8 7/8"
18912	18312	12"	810	8.3	13"	12 1/8"	1 1/2"	2 3/8"	6 3/16"
18914	18314	14"	1230	9.7	14 7/8"	14"	1 1/2"	3 1/8"	7 1/8"
18916	18316	16"	1980	17.3	16 1/2"	15 5/8"	1 1/8"	3 5/8"	14"

* CFM tested at zero static pressure.

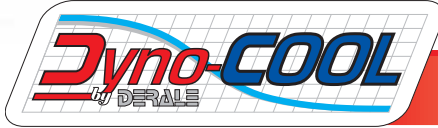

Straight Blade Fans

- Ultra-Low Profile design
- Offered in 5 sizes to fit multiple applications
- Available in two hardware kit options, Manual switch or Thermostatically controlled



WIRING RECOMMENDATIONS:

Fan Kit - Includes mounting kit

Thermostat Kit - Includes mounting kit with adjustable thermostat & wiring

See Pages 12 & 13 for thermostat options

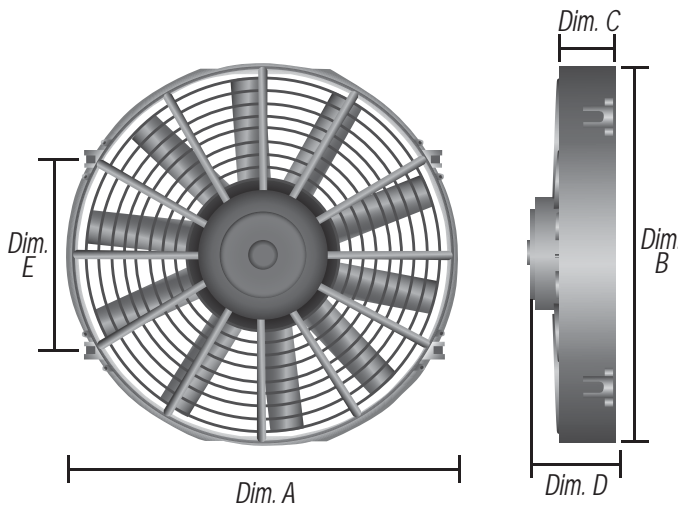

Fan Kit Part No.	Fan & Thermostat Kit Part No.	Fan Size	CFM*	Amp Draw	Dim. A (Width)	Dim. B (Height)	Dim. C (Depth)	Dim. D (Overall Depth)	Dim. E (Mounting)
16908	16308	8"	450	5.3	8 1/8"	8"	1 1/4"	2 1/4"	4 3/8"
16910	16310	10"	500	6.4	11"	11 1/4"	1 1/8"	2 3/8"	5 3/4"
16912	16312	12"	750	9.0	11 3/8"	12 3/8"	1 1/8"	2 3/8"	4 3/4"
16914	16314	14"	1100	12.4	14 1/8"	14 3/4"	1 1/4"	3 1/4"	7 1/8"
16916	16316	16"	1550	15.5	16 7/8"	16 7/8"	1 1/4"	3 7/8"	8 1/8"

* CFM tested at zero static pressure.

ELECTRIC FAN ACCESSORIES

PLASTIC ROD MOUNTING KITS

- Complete mounting kit for mounting an electric fan



Part No.	Description
13001	Plastic Rod Mounting Kit
16744	Plastic Rod Kit with Mounting Feet

COMPLETE PLASTIC ROD INSTALLATION KITS

- Complete installation kit for installing an electric fan



Part No.	Description
16745	Complete Plastic Rod Installation Kit
16742	Complete Plastic Rod Kit with Mounting Feet

METAL ROD MOUNTING KITS

- Complete mounting kit for mounting an electric fan
- Complete installation kit for installing an electric fan



Part No.	Description
16743	Metal Rod Mounting Kit
16741	Complete Metal Rod Installation Kit

HIGH OUTPUT RAD FAN MOUNTING KIT



- Patented adjustable mounting system for Derale part numbers 16212, 16214 & 16217
- For details and photos see page 4



Part No.
16746

RAD FAN BRACKET KITS

- Adjustable metal mounting brackets
- Powdercoat finish



Part No.	Description
16747	Part No. 16927 Mounting Kit
16748	Part No. 16919 Mounting Kit

HIGH OUTPUT DUAL MOUNT BRACKET KIT

- Easily combines any two H.O. single RAD fans for DUAL applications. For details and photos see page 4.



Part No.
16200

Fits Derale part numbers 16212, 16214 & 16217

RELAY WIRE HARNESS KITS



Part No.	Description
16763	40/60 Amp Single Relay Wire Harness
16765	40/60 Amp Dual Relay Wire Harness
16764	40/60 Amp Relay

LIGHTED TOGGLE SWITCH

- 3 Pole, 12 Volt Switch



Part No.
16740

Adjustable Fan Controllers

- Adjustable turn-on temperature from 150-240° F
- Turn-off temperature is preset at 10° F below turn-on temperature
- Removable probe design available in both push-in probe & 3/8" NPT thread-in probe
- Heavy duty 40/60 amp relay
- A/C override circuit included

MAXIMUM CAPACITY: 25 amps



Part#
16749

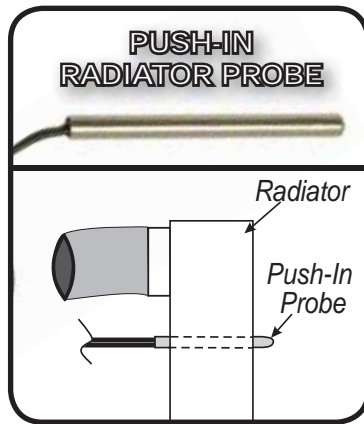
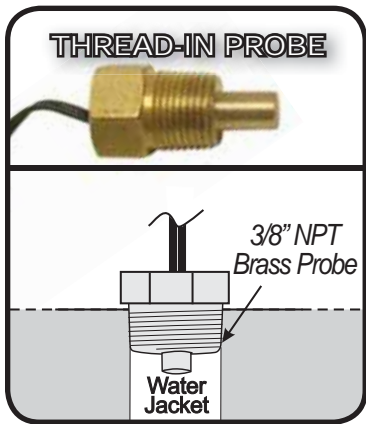

Part No.	Description
16749	3/8" NPT Thread-In Probe
16759	Push-In Radiator Probe
Replacement Probes	
16750	3/8" NPT Thread-In Probe
16760	Push-In Radiator Probe

Mechanical Fan Controller

- Adjustable turn-on temperature from 32-240° F
- Turn-off temperature is preset at 10° F below turn-on temperature
- Radiator hose probe design

MAXIMUM CAPACITY: 16 amps

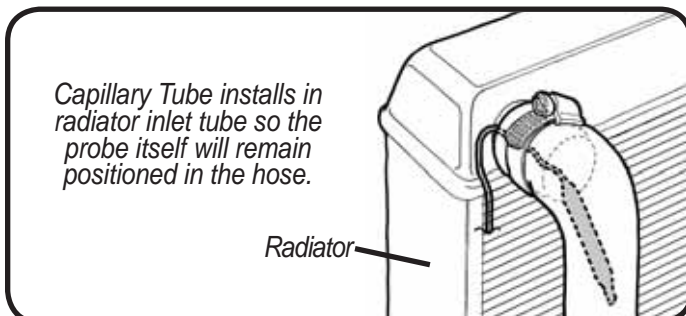
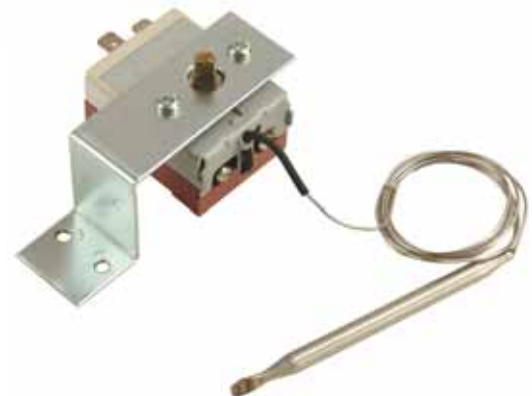

Part No.
16769

SINGLE STAGE FAN CONTROLLERS

Single Stage Fan Controllers

- 180° F preset turn-on temperature
- Turn-off temperature is preset at 165° F
- Removable probe design available in both push-in probe & 3/8" NPT thread-in probe
- New universal kit part number comes with both push-in & thread-in probes



Part# 18735

Premium Series

- Includes Heavy duty 40/60 amp relay harness
- A/C override circuit



Part# 16738

Part No.	Description
Standard Series MAXIMUM CAPACITY: 15 amps	
18735	Universal - Thread-In & Push-In Probe
18738	Push-In Radiator Probe
18739	3/8" NPT Thread-In Probe
Premium Series MAXIMUM CAPACITY: 25 amps	
16735	Universal - Thread-In & Push-In Probe
16738	Push-In Radiator Probe
16739	3/8" NPT Thread-In Probe
Replacement Probes	
16736	Push-In Radiator Probe
16737	3/8" NPT Thread-In Probe

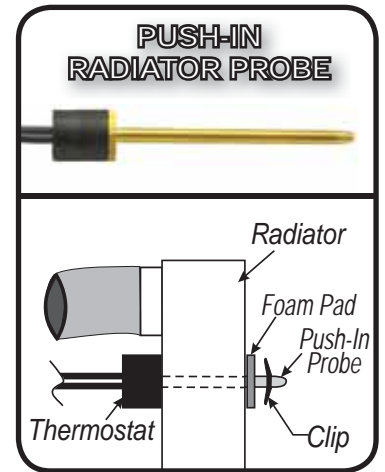
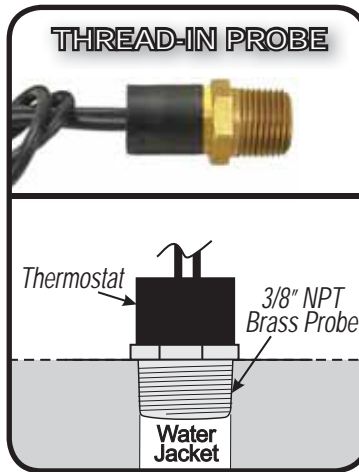

Thread-In Fan Switches

- Available in 2 preset temperatures 180 & 190° F
- Turn-off temperature is preset 15° F below turn-on temperature
- 3/8" NPT x 1/8" NPT bushing included
- Available with & without thermostat Relay harness



Part# 16720

MAXIMUM CAPACITY: 25 amps



Part# 16730

MAXIMUM CAPACITY: 15 amps



Thermostat Relay Kit Part No.	Thermostat Kit Part No.	Temperature	Thread
16720	16730	180° F	1/8" & 3/8" NPT
16721	16731	190° F	1/8" & 3/8" NPT

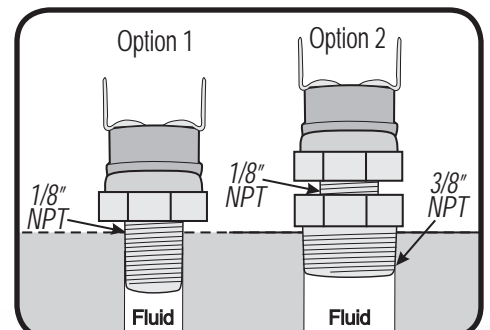

TRANSMISSION PAN COOLERS

- Reduces fluid temperatures 20-50° F
- Heavy-gauge stamped steel construction
- Increases fluid capacity
- Patented turbulator cooling tubes add heat transfer capability
- Zinc plated finish

Derales Transmission Pan Coolers use the air flowing beneath the vehicle to reduce fluid temperatures from 20°F to 50°F. Features include heavy-gauge stamped steel construction, patented turbulator cooling tubes and a zinc plated finish. Increases fluid capacity. Replacement pan gasket included.



Air Flows through the Tubes to Cool the Transmission Fluid

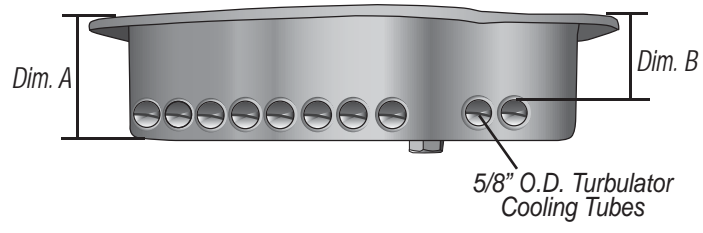

TRANSMISSION PAN MAGNETIC DRAIN PLUG KIT

Increased Magnet Strength

Rubber / Steel Washer

Now Included With Every Pan!

NEW

GM TURBO 350



Fits most GM Turbo 350 1968-1986 applications

GM TURBO 400



Standard - Fits most GM Turbo 400 1966-1990 applications
Deep Pan - Fits most GM Turbo 400 1978-1990 applications

STANDARD
Part# 14101
DEEP
Part# 14102*

Application	Part No.	Extra Capacity	Dim. A (Pan Depth)	Dim. B (Tube Depth)	Repl. Gasket
GM Turbo 350	14100	2 Qts.	3 1/4"	2 1/16"	96900
GM Turbo 400 (Standard)	14101	3 Qts. 8 Oz.	2 7/8"	2"	96901
GM Turbo 400 (Deep)	14102*	Deep OE pan to Deep pan - 1 Qt. 3 Oz. Std. OE pan to Deep pan - 3 Qts. 8 Oz.	4"	3 1/16"	96901

* To change application from a standard depth transmission pan to a deep transmission pan, it will require the purchase of an extended Filter Pickup Tube. Part #14002 (See page 15).

TRANSMISSION PAN COOLERS

The Leader in Performance Cooling



GM 700R4 & 4L60E

Fits most GM 700R4 & 4L60E 1982-1999 applications

Part# 14104



GM 4L80E

Fits most GM 4L80E 1991-2008 applications

Part# 14107



FORD 4R100 & E40D

Fits most Ford E40D & 4R100 1989-2004 applications

Part# 14108



DODGE / CHRYSLER

Fits most Dodge A518, A618, A727, 46RE, 46RH, 47RE & 48RE 1982-2007 applications

Part# 14110



Application	Part No.	Extra Capacity	Dim. A (Pan Depth)	Dim. B (Tube Depth)	Repl. Gasket
GM 700R4, 4L60E	14104	2 Qts. 4 Oz.	3 5/8"	2 3/8"	96906
GM 4L80E	14107	4 Qts. 16 Oz.	4 1/16"	2 3/8"	96909
Ford 4R100, E40D	14108	5 Qts. 2 Oz.	4 3/4"	2 5/8"	96908
Dodge A618, A727, 46RE, 46RH, 47RE & 48RE	14110	A727 to Derale Pan - 5 Qts. 16 Oz. A518 to Derale Pan - 2 Qts. 3 Oz.	4 1/2"	3 5/8"	96905

Transmission Pan Cooler Accessories

FILTER PICKUP TUBE

Application:
GM TH400 deep pan

- Extends filter for use on deep transmission pans



Part# 14002*

DEEP PAN FILTER EXTENDER

Application: Dodge 518, 618, 727

- Extends filter for use on deep transmission pans



Part# 14010

UNIVERSAL DRAIN PLUG KIT

- 1/8" NPT Plug
- Perfect for temp. sending units



Part# 13010

MAGNETIC DRAIN PLUG KIT

- 1/2"-20 Threads
- Increased magnet strength
- Rubber/steel washer



Part# 14000

* To change application from a standard depth transmission pan to a deep transmission pan, it will require the purchase of an extended Filter Pickup Tube. Part #14002.

Performance Electric Fan Kit

APPLICATIONS

1987-1996 Jeep Wrangler YJ
 1997-2006 Jeep Wrangler TJ
 All 4 & 6 cylinder Engines

- Replaces fan clutch, fan shroud & new shroud mounts to factory locations
- Complete kit includes everything you need for a do-it-yourself installation
- Radiator reservoir remount brackets included (used on some 4 & 6 cyl. Applications)
- Power steering remount brackets included (used on some 4 cyl. applications)
- Powdercoated metal shroud
- High Output 265 watt motor
- Thermostatic controlled reliability
- A/C override circuit included
- Easy to follow step-by-step illustrated instructions



NEW

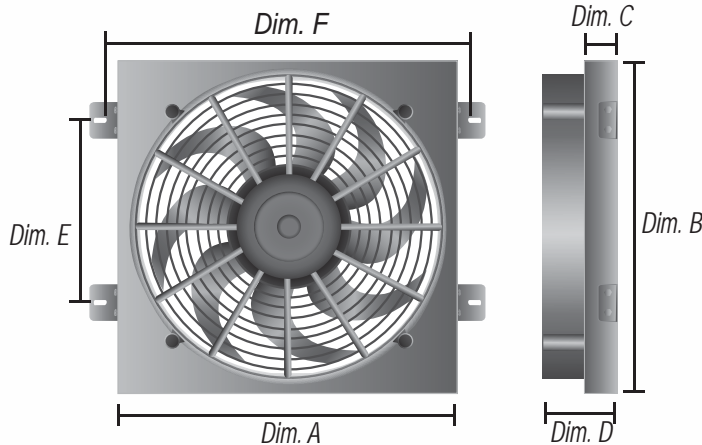

Part No.	Amp Draw	Dim. A (Width)	Dim. B (Height)	Dim. C (Depth)	Dim. D (Overall Depth)	Dim. E (Mounting)	Dim. F (Mounting)
20161	23.5	19 1/2"	18"	1 5/8"	3 5/8"	10"	22 5/8"

DIRECT FIT JEEP KITS**Automatic Transmission Cooler****APPLICATIONS**

1987-1996 Jeep Wrangler YJ
1997-2006 Jeep Wrangler TJ
All 4 & 6 cylinder Engines

- Reduces fluid temperatures 30-40° F
- Perfect for rock crawling and off-road use when airflow is limited
- Complete kit includes everything you need for a do-it-yourself installation
- Dramatically increases transmission life
- Thermostatically controlled electric fan for optimal cooling
- Mounts to frame rail with no drilling

**HARDWARE KIT**

Part No.	Fan Amp Draw
20561	4.8



Hyper-Cool

- Mounts anywhere space permits
- Electric fan supplies optimum airflow
- Extends engine or transmission life
- High efficiency Stacked Plate cooler
- Clear anodized aluminum shroud
- 500 CFM reversible Tornado electric fan
- Available with -6 AN, -8 AN or -10 AN fittings



Part#
15860

Actual hardware kit shown

Cooler Assembly - Includes complete cooler assembly, two aluminum AN fittings (-6 AN, -8 AN or -10 AN) and two brass hose barb fittings (-6 AN x 3/8" barb, -8 AN x 1/2" barb or -10 AN x 1/2" barb)

Transmission Cooler Kit - Includes complete cooler assembly, two aluminum AN fittings (-6 AN or -8 AN), four brass hose barb fittings (-6 AN x 3/8" barb or -8 AN x 1/2" barb), 180°F In-line thermostat, 10 feet of OEM spec hose, 5/16" Insta-dapt radiator fitting, two compression fittings (3/8" x 3/8" hose barb or 1/2" x 1/2" hose barb), four stainless hose clamps and 1/4" mounting hardware

Engine Oil Cooler Kit - Includes complete cooler assembly, Universal* thermostatic sandwich adapter and adapter plate, 13/16-16", 3/4-16", 18mm, 20mm & 22mm sleeve nuts, two aluminum -8 AN fittings, four brass hose barb fittings, 180°F -8 AN In-line thermostat, 10 feet of OEM spec hose, four stainless hose clamps and 1/4" mounting hardware

*Universal application - One part no. fits most automotive applications.

See Engine Adapter Quick Reference Guide on page 36 for specific applications.



Part#
52506

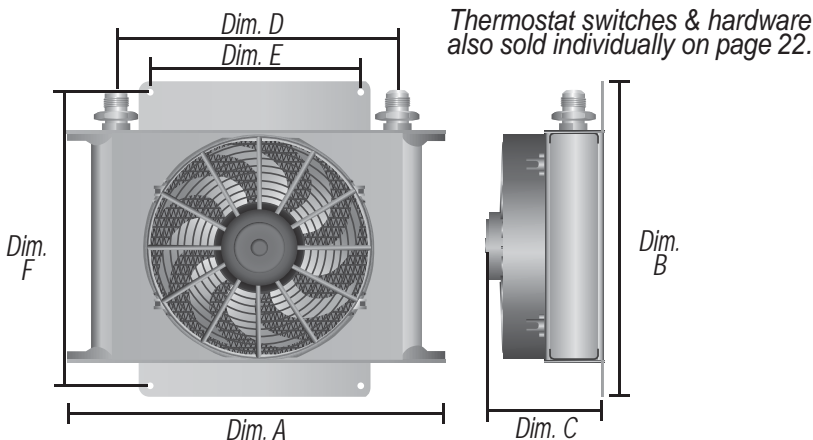

Cooler Assembly Part No.	Cooler Inlet Size	Trans Cooler Kit Part No.	Engine Oil Cooler Kit Part No.	Repl. Core	Dim. A (Width)	Dim. B (Height)	Dim. C (Depth)	Dim. D (Inlets)	Dim. E (Mounting)	Dim. F (Mounting)
13760	-6 AN	13960	-----	52506	13"	10"	5 5/8"	10"	7 1/2"	9"
15860	-8 AN	15960	15660	52508	13"	10"	5 5/8"	10"	7 1/2"	9"
15865	-10 AN	-----	-----	52510	13"	10"	5 5/8"	10"	7 1/2"	9"

REMOTE OIL & TRANSMISSION COOLERS

Atomic-Cool

- Mounts anywhere space permits
- Electric fan supplies optimum airflow
- Extends engine or transmission life
- High efficiency OEM style plate & fin cooler
- Clear anodized aluminum brackets
- 500 CFM reversible Tornado electric fan
- Available with -6 AN or -8 AN fittings



Cooler Assembly - Includes complete cooler assembly, two aluminum AN fittings (-6 AN or -8 AN) and two brass hose barb fittings (-6 AN x 3/8" barb or -8 AN x 1/2" barb)

Transmission Cooler Kit - Includes complete cooler assembly, two aluminum AN fittings (-6 AN or -8 AN), four brass hose barb fittings (-6 AN x 3/8" barb or -8 AN x 1/2" barb), 180°F In-line thermostat, 10 feet of OEM spec hose, 5/16" Insta-dapt radiator fitting, two compression fittings (3/8" x 3/8" hose barb or 1/2" x 1/2" hose barb), four stainless hose clamps and 1/4" mounting hardware

Engine Oil Cooler Kit - Includes complete cooler assembly, Universal* thermostatic sandwich adapter and adapter plate, 13/16-16", 3/4-16", 18mm, 20mm & 22mm sleeve nuts, two aluminum -8 AN fittings, four brass hose barb fittings, 180°F -8 AN In-line thermostat, 10 feet of OEM spec hose, four stainless hose clamps and 1/4" mounting hardware

*Universal application - One part no. fits most automotive applications.

See Engine Adapter Quick Reference Guide on page 36 for specific applications.

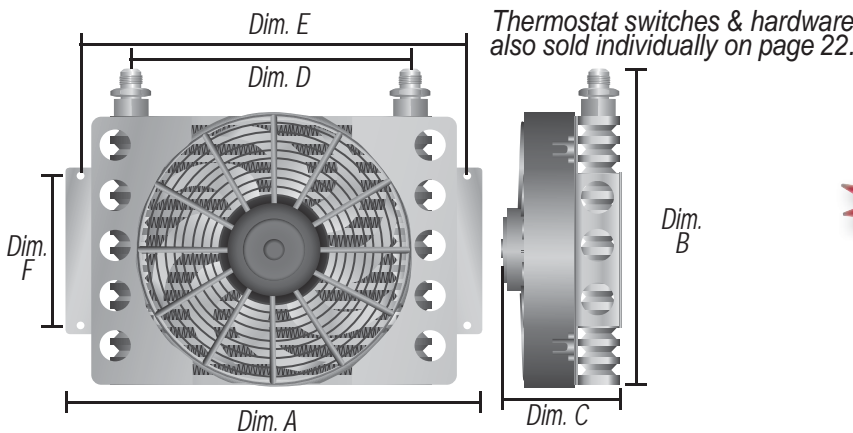

Cooler Assembly Part No.	Cooler Inlet Size	Trans Cooler Kit Part No.	Engine Oil Cooler Kit Part No.	Repl. Core	Dim. A (Width)	Dim. B (Height)	Dim. C (Depth)	Dim. D (Inlets)	Dim. E (Mounting)	Dim. F (Mounting)
13750	-6 AN	13950	-----	13751	12 3/4"	9 3/8"	4 5/16"	8 9/16"	11 5/8"	4"
15850	-8 AN	15950	15450	15851	12 3/4"	9 3/8"	4 5/16"	8 9/16"	11 5/8"	4"

Electra-Cool

- Mounts anywhere space permits
- Electric fan supplies optimum airflow
- Extends engine or transmission life
- Offered in 16 pass & 8 pass tube & fin cooler core
- Clear anodized aluminum brackets
- 650 CFM reversible Tornado electric fan
- Available with -6 AN or -8 AN fittings



REVERSIBLE

Actual hardware kit shown

Cooler Assembly - Includes complete cooler assembly, two aluminum AN fittings (-6 AN or -8 AN) and two brass hose barb fittings (-6 AN x 3/8" barb or -8 AN x 1/2" barb)

Transmission Cooler Kit - Includes complete cooler assembly, two aluminum AN fittings (-6 AN or -8 AN), four brass hose barb fittings (-6 AN x 3/8" barb or -8 AN x 1/2" barb), 180°F In-line thermostat, 10 feet of OEM spec hose, 5/16" Insta-dapt radiator fitting, two compression fittings (3/8" x 3/8" hose barb or 1/2" x 1/2" hose barb), four stainless hose clamps and 1/4" mounting hardware

Engine Oil Cooler Kit - Includes complete cooler assembly, Universal* thermostatic sandwich adapter and adapter plate, 13/16-16", 3/4-16", 18mm, 20mm & 22mm sleeve nuts, two aluminum -8 AN fittings, four brass hose barb fittings, 180°F - 8 AN In-line thermostat, 10 feet of OEM spec hose, four stainless hose clamps and 1/4" mounting hardware

*Universal application - One part no. fits most automotive applications.

See Engine Adapter Quick Reference Guide on page 36 for specific applications.

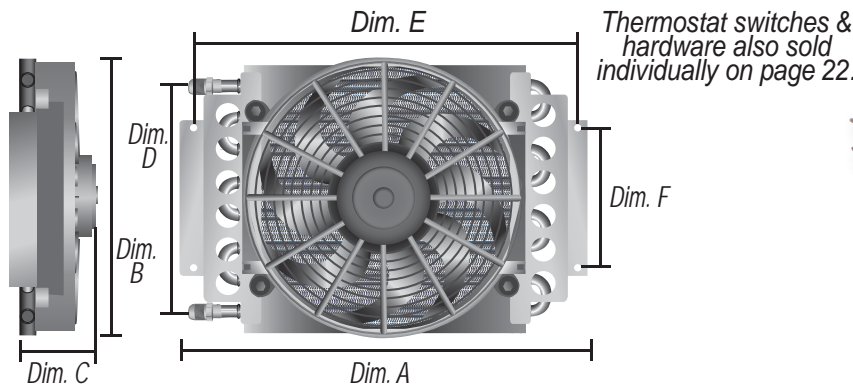

Cooler Assembly Part No.	Cooler Inlet Size	Trans Cooler Kit Part No.	Engine Oil Cooler Kit Part No.	Repl. Core	Dim. A (Width)	Dim. B (Height)	Dim. C (Depth)	Dim. D (Inlets)	Dim. E (Mounting)	Dim. F (Mounting)
13700	-6 AN	13900	----	13300	15 3/4"	11 1/2"	5"	8 3/4"	14 3/4"	5 1/4"
15800	-8 AN	15900	15500	15300	15 3/4"	11 1/2"	5"	8 3/4"	14 3/4"	5 1/4"
13720	-6 AN	----	----	13320	15 3/4"	11 1/2"	4"	8 3/4"	14 3/4"	5 1/4"
15820	-8 AN	----	----	15320	15 3/4"	11 1/2"	4"	8 3/4"	14 3/4"	5 1/4"

REMOTE OIL & TRANSMISSION COOLERS

The Leader in Performance Cooling

Econo-Cool

- Efficient copper/aluminum tube & fin cooler
- Offered in 11/32" and 1/2" barb inlets

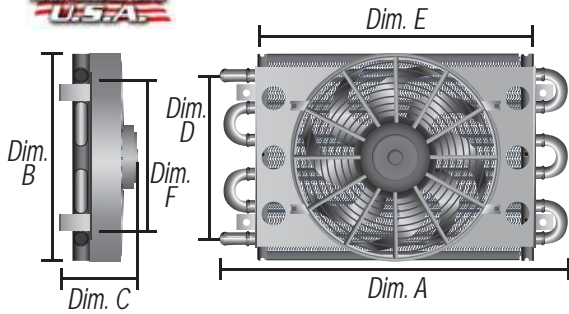

Part#
15830

Recommended for:
 Transmissions
 Power Steering
 Fuel

Cooler Assembly Part No.	Cooler Inlet Size	Repl. Core	Dim. A (Width)	Dim. B (Height)	Dim. C (Depth)	Dim. D (Inlets)	Dim. E (Mounting)	Dim. F (Mounting)
13730	11/32" Barb	13731	12 3/4"	7 5/8"	3 3/4"	6 1/4"	11"	5"
15830	1/2" Barb	15831	12 3/4"	7 5/8"	3 3/4"	6 1/4"	11"	5"

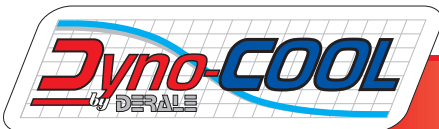

Remote Coolers

- Efficient copper/aluminum tube & fin cooler
- Offered in 4 sizes with 11/32" barb or -6 AN inlets

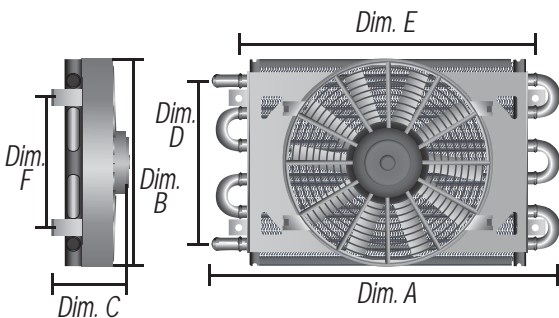

Part#
12740

Recommended for:
 Transmissions
 Power Steering
 Fuel

Cooler Assembly -6 AN Inlets Part No.	Cooler Assembly 11/32" Barb Inlets Part No.	Core	Dim. A (Width) -6 AN / 11/32"	Dim. B (Height)	Dim. C (Depth)	Dim. D (Inlets)	Dim. E (Mounting)	Dim. F (Mounting)
12730	12740	6 Pass	13 5/8" / 12 3/4"	7 5/8"	3 5/8"	6 1/4"	11"	5"
12731	12741	6 Pass	17 1/2" / 16 5/8"	7 5/8"	3 3/4"	6 1/4"	14 3/4"	5"
12732	12742	8 Pass	13 5/8" / 12 3/4"	10 1/4"	3 5/8"	8 3/4"	11"	5"
12733	12743	8 Pass	17 1/2" / 16 5/8"	10 1/4"	3 3/4"	8 3/4"	14 3/4"	5"

In-line Fluid Thermostats

Standard Series

- 180°F preset turn-on temperature
- Turn-off temperature is preset at 165°F
- Avail. in -6 AN or -8 AN aluminum housing
- Brass hose barb fittings included



MAXIMUM CAPACITY: 15 amps

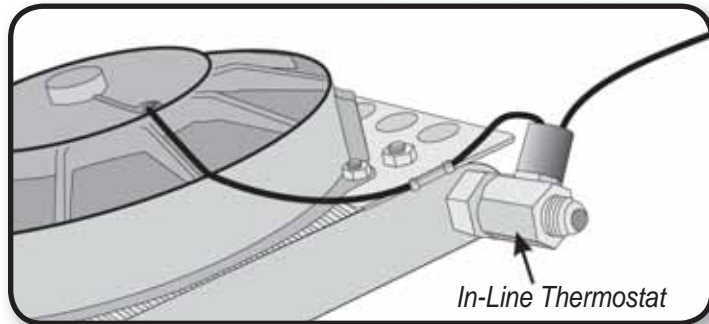

Premium Series



- Avail. in 180°F & 190°F turn-on temp
- Turn-off temperature is preset 15°F below turn-on temperature
- Available in -6 AN, -8 AN or -10 AN aluminum fittings
- New anodized aluminum swivel housing

MAXIMUM CAPACITY: 15 amps



180°F Part No.	190°F Part No.	Description
Standard Series		
13021	-----	-6 AN x -6 AN
15721	-----	-8 AN x -8 AN
Premium Series		
35020	35025	-6 AN x -6 AN
35021	35026	-8 AN x -8 AN
35022	35027	-10 AN x -10 AN
16730	16731	Thermostat Only

Remote Cooler Mounting Kits

TRANSMISSION COOLER KITS

- Offered with 5/16", 3/8" or 1/2" cooler line compression fittings to fit every application

Transmission Cooler Kit - Includes In-line thermostat, 10 feet OEM spec hose, 5/16" Insta-dapt adapter, two compression fittings and mounting hardware



Part No.	Description
13020	5/16" Cooler lines 3/8" Hose Barb
13022	3/8" Cooler lines 3/8" Hose Barb
13023	1/2" Cooler lines 1/2" Hose Barb

ENGINE OIL COOLER KIT

Engine Oil Cooler Kit - Includes universal* thermostatic sandwich adapter and adapter plate, 13/16-16", 3/4-16", 18mm, 20mm & 22mm sleeve nuts, 180°F In-line thermostat, 10 feet OEM spec hose, and mounting hardware

*Universal application - One part no. fits most automotive applications. See Engine Adapter Quick Reference Guide on page 36 for specific applications.



Part No.	Description
15752	Most Applications

FLUID COOLER ACCESSORIES

SINGLE HOSE COOLER INSTALLATION KIT

- Complete installation kit for mounting most transmission coolers
- Four feet 11/32" OEM spec hose



Part No. 13006

INSTA-MOUNT KIT

- Universal mounting kit for coolers & electric fans



Part No. 13001

DUAL HOSE COOLER INSTALLATION KIT

- Complete installation kit for mounting most transmission coolers
- Eight feet 11/32" OEM spec hose



Part No. 13064

RIGID MOUNT KIT

- Universal bendable metal mounting brackets



Part No. 13002

UNIVERSAL DRAIN PLUG KIT

- 1/8" NPT Plug
- Perfect for temperature sending units



Part No. 13010

OIL TEMPERATURE GAUGE

- Transmission or Engine oil temperature
- 2-5/8" diameter electric gauge includes mounting bracket, 1/8" NPT sensor and transmission pan adapter/drain plug to mount sensor in pan



Part No. 13009

STAINLESS HOSE CLAMPS

- Universal hose clamps, fits from 5/16" to 1/2" hose



Part No. 13008

REPLACEMENT OIL HOSE

- Transmission or Engine oil hose
- High temperature, high pressure OEM spec hose



Part# 13003

Part# 13007

Part No.	Hose ID	Length	Application
13003	11/32"	4 feet	Transmission
13007	11/32"	25 feet	Transmission
13016	3/8"	5 feet	Transmission
13017	3/8"	25 feet	Transmission
15700	1/2"	10 feet	Engine
15701	1/2"	5 feet	Engine
15799	1/2"	25 feet	Engine

STACKED PLATE COOLERS

- Designed for Engine or Transmission cooling
- Most efficient heat exchangers available
- Furnace brazed aluminum construction with 4 integrated mounting brackets
- Available in 4 cooler sizes, 10, 16, 19 & 25 rows
- Available with aluminum AN fittings
- Cooler Kit with fittings offered in -6 AN, -8 AN & -10 AN
- -10 AN / 7/8"-14 O-ring cooler inlets

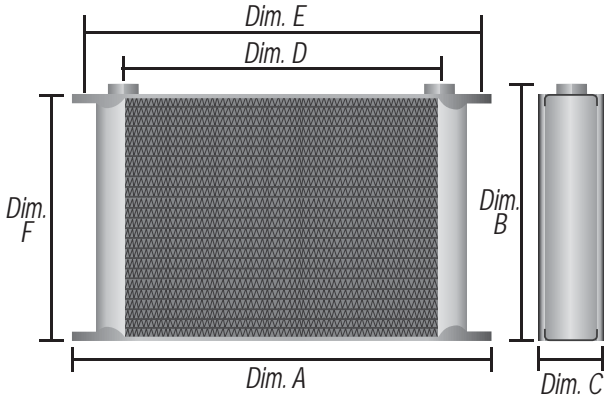

Recommended for:
 Transmissions
 Engines
 Power Steering
 Fuel
 Differentials



More Efficient, High Pressure Cooler Design

Part No.	Inlet Size	Dim. A (Width)	Dim. B (Height)	Dim. C (Depth)	Dim. D (Inlets)	Dim. E (Mounting)	Dim. F (Mounting)
Cooler Only							
51078	-10 AN O-ring Female	13"	3 9/16"	2"	11"	12 1/4"	2 7/8"
51678	-10 AN O-ring Female	13"	5 9/16"	2"	11"	12 1/4"	4 7/8"
51978	-10 AN O-ring Female	13"	6 7/16"	2"	11"	12 1/4"	5 3/4"
52578	-10 AN O-ring Female	13"	8 5/16"	2"	11"	12 1/4"	7 5/8"
Cooler Kit (With Fittings)							
51006	-6 AN Male	13"	4 7/16"	2"	11"	12 1/4"	2 7/8"
51008	-8 AN Male		4 9/16"				
51010	-10 AN Male		4 11/16"				
51606	-6 AN Male	13"	6 7/16"	2"	11"	12 1/4"	4 7/8"
51608	-8 AN Male		6 9/16"				
51610	-10 AN Male		6 11/16"				
51906	-6 AN Male	13"	7 5/16"	2"	11"	12 1/4"	5 3/4"
51908	-8 AN Male		7 7/16"				
51910	-10 AN Male		7 9/16"				
52506	-6 AN Male	13"	9 3/16"	2"	11"	12 1/4"	7 5/8"
52508	-8 AN Male		9 5/16"				
52510	-10 AN Male		9 9/16"				

STACKED PLATE COOLERS

Transmission Cooler Kits

- Prevents heat related transmission failures
- Improves transmission performance
- -6 AN aluminum fittings & hose barb adapters included
- Complete hardware kit included

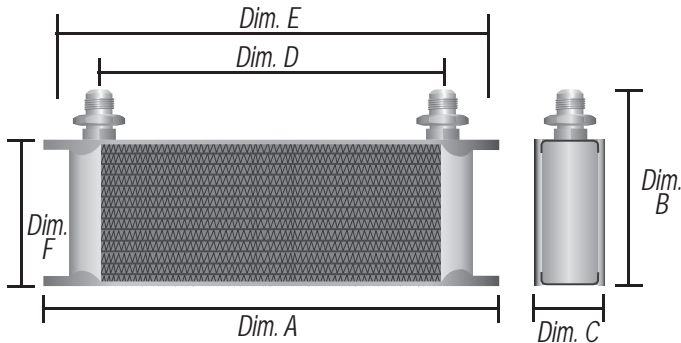

Part No.	Dim. A (Width)	Dim. B (Height)	Dim. C (Depth)	Dim. D (Inlets)	Dim. E (Mounting)	Dim. F (Mounting)
13401	13"	4 7/16"	2"	11"	12 1/4"	2 7/8"
13402	13"	6 7/16"	2"	11"	12 1/4"	4 7/8"

Aluminum Cooler Fittings & Mounting Brackets

- Offered in -6 AN, -8 AN, -10 AN & -12 AN

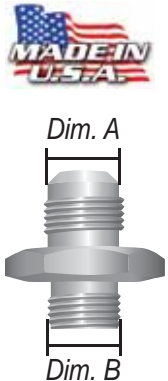

NEW

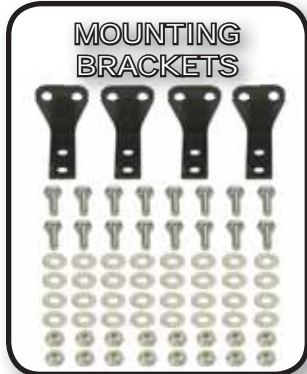

NEW Part# 50020

- New 4 way bracket system
- Black powdercoat finish



Part No.	Dim. A	Dim. B	U/M
59006	-6 AN	-10 AN / 7/8"-14 O-ring	Each
59008	-8 AN	-10 AN / 7/8"-14 O-ring	Each
59010	-10 AN	-10 AN / 7/8"-14 O-ring	Each
59012	-12 AN	-10 AN / 7/8"-14 O-ring	Each
50020	Bracket Kit - 4 mounting brackets		Set



Series 9000 Plate & Fin Cooler Kits

- Prevents heat related transmission failures
- Extends life of transmission
- Improves transmission performance
- Sturdy furnace-brazed aluminum construction
- 1 1/4" turbulators maximize cooling & minimize pressure drop
- New 1/2" NPT female cooler fittings
- 1/2" NPT x 3/8" hose barb adapters included
- Complete hardware kit included

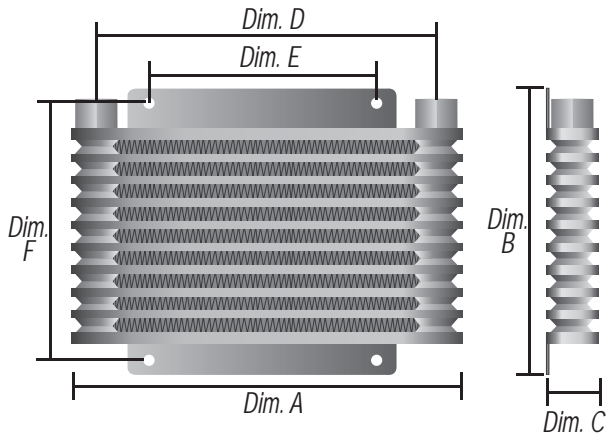

Part No.	GVW	Dim. A (Width)	Dim. B (Height)	Dim. C (Depth)	Dim. D (Inlets)	Dim. E (Mounting)	Dim. F (Mounting)
13611	14000	10 1/8"	3 7/8"	1 1/4"	8 7/8"	6 3/4"	3"
13612	17500	10 1/8"	6 3/8"	1 1/4"	8 7/8"	6 3/4"	5 1/2"
13613	22000	10 1/8"	8 7/8"	1 1/4"	8 7/8"	6 3/4"	8"
13614	24000	10 1/8"	11 7/8"	1 1/4"	8 7/8"	6 3/4"	10 1/2"



TRANSMISSION COOLERS

Series 8000 Plate & Fin Cooler Kits

- Prevents heat related transmission failures
- Extends life of transmission
- Improves transmission performance
- 3/4" embossed turbulators maximize cooling & minimize pressure drop
- Sturdy furnace-brazed aluminum construction
- 11/32" hose barb inlets
- Complete hardware kit included

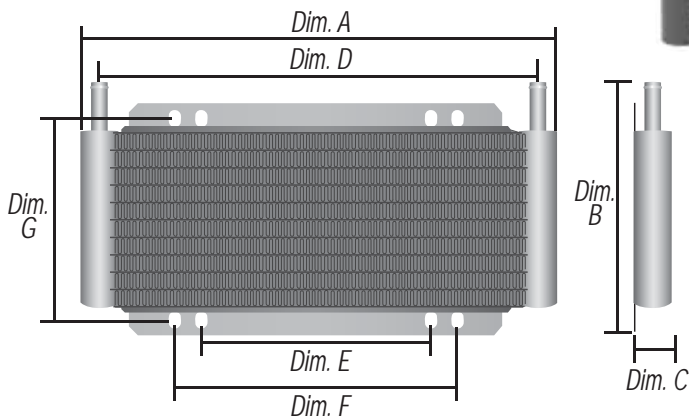

Part No.	GVW	Dim. A (Width)	Dim. B (Height)	Dim. C (Depth)	Dim. D (Inlets)	Dim. E (Mounting)	Dim. F (Mounting)	Dim. G (Mounting)
13501	15500	11"	5 3/4"	7/8"	10 1/4"	5 1/4"	6 3/4"	4 1/2"
13502	17500	11"	7 1/4"	7/8"	10 1/4"	5 1/4"	6 3/4"	6 1/8"
13503	20500	11"	8 3/4"	7/8"	10 1/4"	5 1/4"	6 3/4"	8"
13504	22500	11"	12"	7/8"	10 1/4"	5 1/4"	6 3/4"	10 1/2"



Series 7000 Tube & Fin Cooler Kits

- Prevents heat related transmission failures
- Extends life of transmission
- Improves transmission performance
- 1/2" copper tubing expanded into aluminum cooling fins
- 11/32" hose barb inlets
- Embossed turbulators inserted in each tube agitate fluid for maximum heat transfer
- Extruded plastic cooling fin guards
- Offered in 8 sizes to fit any application
- Complete hardware kit included

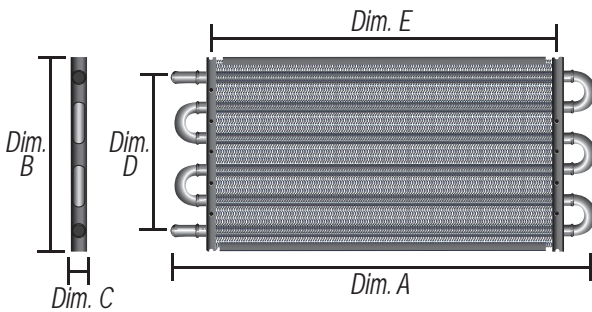

Display Box	Display Board	GVW	Dim. A (Width)	Dim. B (Height)	Dim. C (Depth)	Dim. D (Inlets)	Dim. E (Mounting)
13101	13201	12000	12 3/4"	5 1/8"	3/4"	3 3/4"	9 5/8"
13102	13202	14000	16 5/8"	5 1/8"	3/4"	3 3/4"	13 3/4"
13103	13203	18500	16 5/8"	7 5/8"	3/4"	6 1/4"	13 3/4"
13104	13204	20500	16 5/8"	10 1/4"	3/4"	8 3/4"	13 3/4"
13105	13205	22500	16 5/8"	12 5/8"	3/4"	11 1/4"	13 3/4"
13106	13206	15500	12 3/4"	7 5/8"	3/4"	6 1/4"	9 5/8"
13107	13207	18200	12 3/4"	10 1/4"	3/4"	8 3/4"	9 5/8"
13108	13208	20500	12 3/4"	12 5/8"	3/4"	11 1/4"	9 5/8"

TRANSMISSION COOLERS

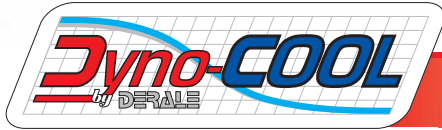

Aluminum Tube & Fin Cooler Kits

- Prevents heat related transmission failures
- Extends life of transmission
- Improves transmission performance
- 1/2" aluminum tubing expanded into aluminum cooling fins
- 11/32" hose barb inlets
- Embossed turbulators inserted in each tube agitate fluid for maximum heat transfer
- Offered in 6 sizes to fit any application
- Complete hardware kit included

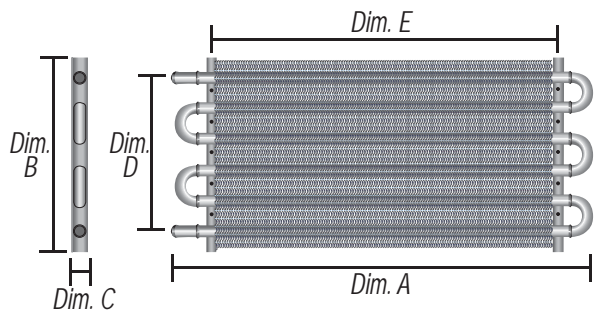

Part No.	GVW	Dim. A (Width)	Dim. B (Height)	Dim. C (Depth)	Dim. D (Inlets)	Dim. E (Mounting)
12901	12000	13"	5"	3/4"	3 3/4"	10 1/8"
12902	14000	15 1/4"	5"	3/4"	3 3/4"	12 1/4"
12903	18500	15 1/4"	7 1/2"	3/4"	6 1/4"	12 1/4"
12904	20500	15 1/4"	10"	3/4"	8 3/4"	12 1/4"
12906	15500	13"	7 1/2"	3/4"	6 1/4"	10 1/8"
12907	18200	13"	10"	3/4"	8 3/4"	10 1/8"

Series 7000 AN Tube & Fin Cooler Kits

- -6 AN male cooler ports
- Rubber hose with -6 AN female hose ends
- 1/2" copper tubing expanded into aluminum cooling fins
- Complete hardware kit included

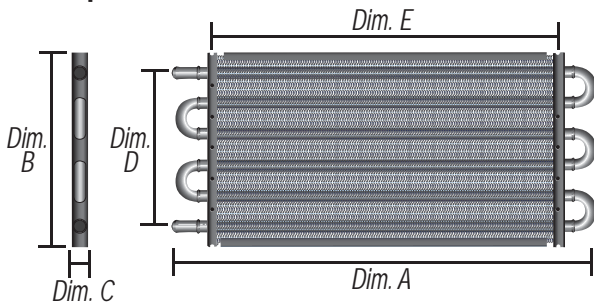

Part No.	GVW	Dim. A (Width)	Dim. B (Height)	Dim. C (Depth)	Dim. D (Inlets)	Dim. E (Mounting)
13303	18500	17 1/2"	7 5/8"	3/4"	6 1/4"	13 3/4"
13304	20500	17 1/2"	10 1/4"	3/4"	8 3/4"	13 3/4"
13306	15500	13 5/8"	7 5/8"	3/4"	6 1/4"	9 5/8"

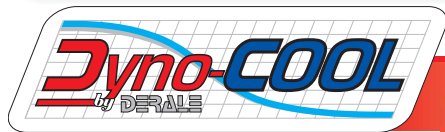

Aluminum SAE Tube & Fin Cooler Kits

- 9/16"-18 45° SAE female swivel fittings
- Hose barb adapter fittings included
- All aluminum cooler construction
- Complete hardware kit included

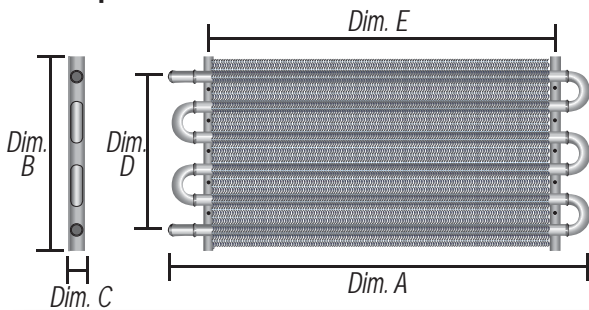

Part No.	GVW	Dim. A (Width)	Dim. B (Height)	Dim. C (Depth)	Dim. D (Inlets)	Dim. E (Mounting)
12303	18500	15 1/2"	7 1/2"	3/4"	6 1/4"	12 1/4"
12304	20500	15 1/2"	10"	3/4"	8 3/4"	12 1/4"
12306	15500	13 1/2"	7 1/2"	3/4"	6 1/4"	10 1/8"



COOLER CORES

Series 7000 AN Tube & Fin Cooler Cores

- 1/2" copper tubing expanded into aluminum cooling fins
- -6 AN male cooler fittings
- Extruded plastic cooling fin guards
- Embossed turbulators in each tube agitate fluid for maximum heat transfer
- Offered in 8 sizes to fit any application
- No hardware kit included



Recommended for:
 Transmissions
 Power Steering
 Fuel

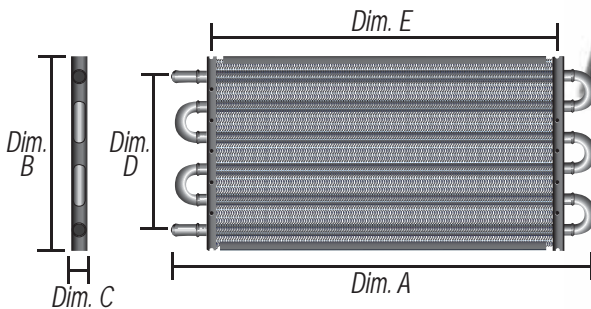

Part No.	GVW	Dim. A (Width)	Dim. B (Height)	Dim. C (Depth)	Dim. D (Inlets)	Dim. E (Mounting)
13311	12000	13 1/2"	5 1/8"	3/4"	3 3/4"	9 5/8"
13312	14000	17 1/2"	5 1/8"	3/4"	3 3/4"	13 3/4"
13313	18500	17 1/2"	7 5/8"	3/4"	6 1/4"	13 3/4"
13314	20500	17 1/2"	10 1/4"	3/4"	8 3/4"	13 3/4"
13315	22500	17 1/2"	12 5/8"	3/4"	11 1/4"	13 3/4"
13316	15500	13 1/2"	7 5/8"	3/4"	6 1/4"	9 5/8"
13317	18200	13 1/2"	10 1/4"	3/4"	8 3/4"	9 5/8"
13318	20500	13 1/2"	12 5/8"	3/4"	11 1/4"	9 5/8"

Transmission Coolers Kits

- Prevents heat related transmission failures
- Extends life of transmission
- Improves transmission performance
- 1/2" copper tubing expanded into aluminum cooling fins
- Embossed turbulators in each tube agitate fluid for maximum heat transfer
- 1 1/32" hose barb inlets
- Extruded plastic cooling fin guards

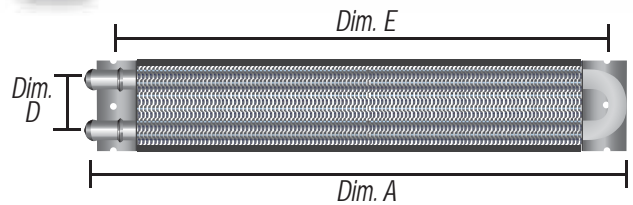
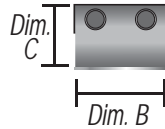

Part No.	Dim. A (Length)	Dim. B (Width)	Dim. C (Depth)	Dim. D (Inlets)	Dim. E (Mounting)
13220	16 3/4"	1 3/4"	2 1/2"	1 1/4"	15 1/2"
13222	12 3/4"	1 3/4"	2 1/2"	1 1/4"	11 3/4"
13224	23 3/4"	1 3/4"	2 1/2"	1 1/4"	22 3/4"



Fluid Coolers

- 1/2" copper tubing expanded into aluminum cooling fins
- Embossed turbulators in each tube agitate fluid for maximum heat transfer
- -6 AN male cooler fittings
- Extruded plastic cooling fin guards

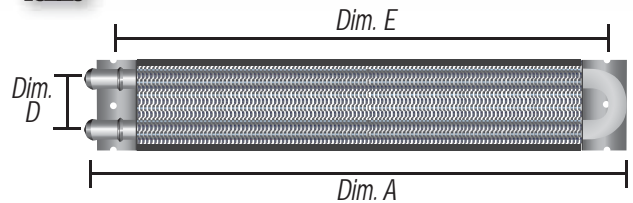
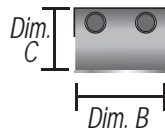

Recommended for:
 Transmissions
 Power Steering
 Fuel

Part No.	Dim. A (Length)	Dim. B (Width)	Dim. C (Depth)	Dim. D (Inlets)	Dim. E (Mounting)
13221	17 3/4"	1 3/4"	2 1/2"	1 1/4"	15 1/2"
13223	13 3/4"	1 3/4"	2 1/2"	1 1/4"	11 3/4"
13225	24 3/4"	1 3/4"	2 1/2"	1 1/4"	22 3/4"



HEAT SINK COOLERS

The Leader in Performance Cooling

- Aluminum Heat Sink design produces high heat transfer
- External & Internal heat dissipating fins
- Available in 5 sizes to fit any application
- Offered in single & dual pass designs
- Compact 3" diameter to fit most frame rails

Recommended for:
 Transmissions
 Engines
 Power Steering
 Fuel
 Differentials

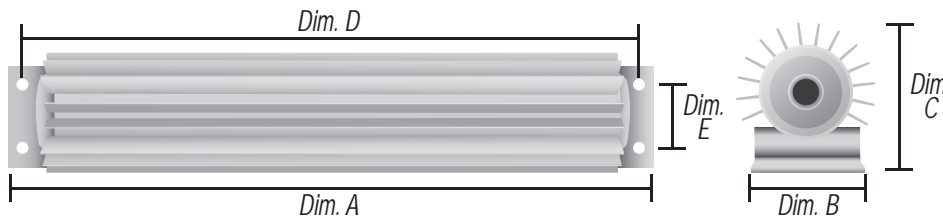
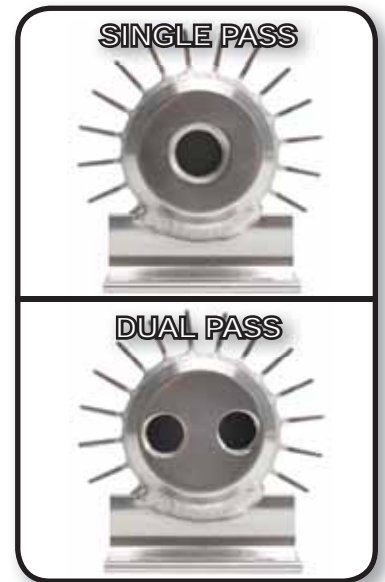
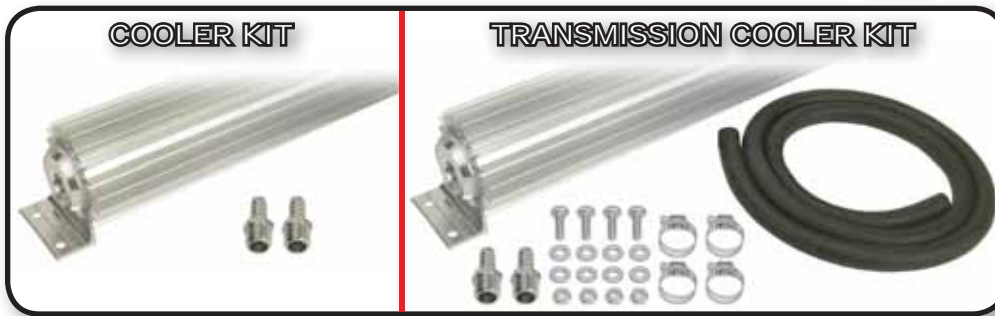

Cooler Kit Part No.	Trans. Cooler Kit Part No.	Inlet(s) Size	Dim. A (Length)	Dim. B (Width)	Dim. C (Depth)	Dim. D (Mounting)	Dim. E (Mounting)
Single Pass							
13249	-----	3/8" NPT	10 1/4"	2 3/16"	3 1/4"	9 5/8"	1 3/8"
13250	13253	3/8" NPT	14 1/4"	2 3/16"	3 1/4"	13 5/8"	1 3/8"
13251	13254	3/8" NPT	17 1/4"	2 3/16"	3 1/4"	16 5/8"	1 3/8"
13252	13255	3/8" NPT	20 1/4"	2 3/16"	3 1/4"	19 5/8"	1 3/8"
13257	13256	3/8" NPT	26 1/4"	2 3/16"	3 1/4"	25 5/8"	1 3/8"
Dual Pass							
13260	13263	1/4" NPT	14 1/4"	2 3/16"	3 1/4"	13 5/8"	1 3/8"
13261	13264	1/4" NPT	17 1/4"	2 3/16"	3 1/4"	16 5/8"	1 3/8"
13262	13265	1/4" NPT	20 1/4"	2 3/16"	3 1/4"	19 5/8"	1 3/8"
13267	13266	1/4" NPT	26 1/4"	2 3/16"	3 1/4"	25 5/8"	1 3/8"

Radiator Adapter Fittings



Barbed Splicer Fittings

DODGE/JEEP RADIATOR ADAPTER

Fits 1960-1997 Dodge Trucks with rubber transmission lines
Fits 1983-2007 Jeep with 5.2L, 4.2L, 4.0L, 2.5L Engines with rubber transmission lines

Part No. 13028



1/2"-20 Inverted Flare Fittings

FORD/LINCOLN/MERCURY RADIATOR ADAPTER

Fits 1983-2007 Ford/Lincoln/Mercury Cars, Trucks, Blackwood, Bronco, Expedition, Navigator, Ranger, Vans with 7.3L, 6.9L, 5.8L, 5.0L, 4.9L, 4.6L, 4.2L, 2.9L, 2.8L, 2.3L Engines

Part No. 13024



9/16"-18 37° JIC Fitting

DODGE DAKOTA RADIATOR ADAPTER

Fits 1999-2005 Dodge Dakota

Part No. 13030



9/16"-24 45° SAE Fittings Male & Female

DODGE RADIATOR ADAPTER

Fits 1999-2003 Dodge Trucks, Vans with 5.9L, 5.2L, 3.9L Engines

Part No. 13034



5/8" Inverted Flare Fittings

GM RADIATOR ADAPTER

Fits 1981-2000 Buick w/ 5.7L, 3.8L, 3.3L, 3.1L, 2.5L, 2.4L, 2.3L, 2.2L Engines

Fits 1988-2007 Cadillac Cars, Trucks with 6.2L, 6.0L, 5.7L, 5.3L, 4.9L, 4.6L, 4.5L, 4.1L, 3.0L Engines

Fits 1987-2007 Chevrolet Cars, SUVs, Chevrolet, GM Trucks, Vans w/ 8.1L, 7.4L, 6.5L, 6.0L, 5.7L, 5.3L, 5.0L, 4.8L, 4.3L, 3.8L, 3.4L, 3.2L, 2.4L, 2.3L, 2.2L Engines

Fits 1996-2001 Oldsmobile Bravada with 4.3L Engine

Fits 1983-2005 Pontiac Cars, SUVs with 5.7L, 5.0L, 3.8L, 3.4L, 3.1L, 2.4L, 2.2L, 1.6L Engines

Part No. 13018



1/4" NPT M/F 3/8" NPT Male Fittings

FORD/MERCURY RADIATOR ADAPTER

Fits 1983-2007 Ford/Mercury Cars, Trucks, Bronco, Expedition, Ranger, Vans w/ 7.5L, 7.3L, 6.9L, 6.6L, 5.8L, 5.4L, 5.0L, 4.9L, 4.7L, 4.6L, 4.2L, 4.0L, 3.8L, 3.0L, 2.9L, 2.8L, 2.5L, 2.3L Engines

Fits 1983-2007 Mercury Cars w/ 5.8L, 5.0L, 4.6L, 3.8L, 3.0L, 2.5L, 2.3L Engines

Part No. 13014



5/8" Inverted Flare Fittings

FORD/LINCOLN TRUCKS & SUV'S RADIATOR ADAPTER

Fits 1998-2007 Ford/Lincoln Trucks & SUV's, Blackwood, Excursion, Expedition, Explorer, Navigator, Ranger with 7.3L, 6.9L, 6.8L, 5.4L, 5.0L, 4.6L, 4.0L, 3.0L, 2.5L Engines

Part No. 13025



Snap in Tube Fitting

GM RADIATOR ADAPTER

Fits 1993-2007 Buick with 4.6L, 4.2L, 3.9L, 3.8L, 3.6L, 3.5L, 3.4L, 3.3L, 2.5L, 2.4L, 2.3L, 2.2L Engines

Fits 1993-2007 Cadillac 6.2L, 6.0L, 5.7L, 5.3L, 4.9L, 4.6L, 4.5L, 4.1L, 3.0L Engines

Fits 2000-2007 Chevrolet Cars, SUVs, Chevrolet, GM Trucks, Vans with 3.8L, 3.4L, 6.0L, 5.3L, 4.8L, 4.3L, 4.2L, 3.7L, 3.5L, 3.4L, 2.9L, 2.8L Engines

Fits 2003-2007 Isuzu SUVs with 4.2L, 5.3L Engines

Fits 2002-2004 Oldsmobile Bravada with 4.2L Engine

Fits 2001-2007 Pontiac with 3.9L, 3.8L, 3.5L, 3.4L, 3.1L Engines

Part No. 13035

Universal Transmission Line Fittings



5/16" Transmission Cooler Line to 3/8" NPT Hose Barb

Part No. 13031



3/8" Transmission Cooler Line to 3/8" NPT Hose Barb

Part No. 13032



1/2" Transmission Cooler Line to 1/2" NPT Hose Barb

Part No. 13033

INSTA-DAPT RADIATOR ADAPTER



Fits most vehicles with 5/16" transmission lines. Includes male and female threads.

Part No. 13004

See application guide for detail specific applications

POWER STEERING COOLER KITS

Tube & Fin

- Extends pump & seal life
- Reduces heat related pump failure
- 1/2" copper tubing expanded into aluminum cooling fins
- 11/32" hose barb inlets
- Extruded plastic cooling fin guards

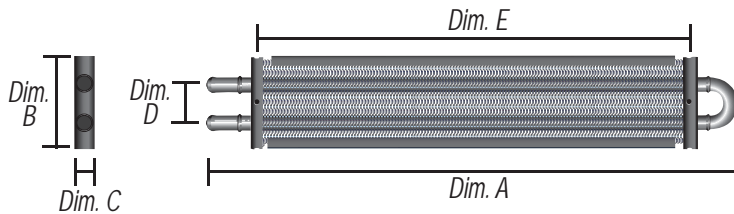

Part No.	Dim. A (Width)	Dim. B (Height)	Dim. C (Depth)	Dim. D (Inlets)	Dim. E (Mounting)
13200	12 5/8"	2 1/2"	3/4"	1 1/4"	10"
13210	8 1/8"	2 1/2"	2 1/2"	1 1/4"	5 1/4"
13212	8 1/8"	5"	3/4"	3 3/4"	5 1/4"
13213	8 1/8"	2 1/2"	3/4"	1 1/4"	5 1/4"

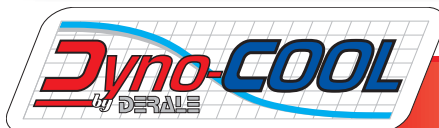

Aluminum Tube & Fin

- Extends pump & seal life
- Reduces heat related pump failure
- All aluminum cooler construction
- 11/32" hose barb inlets

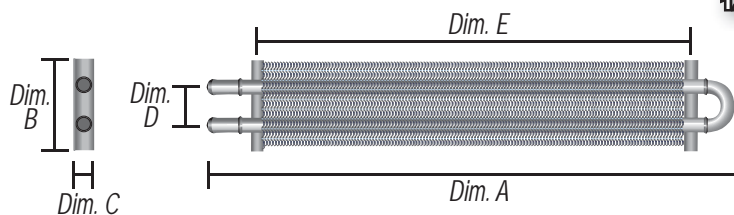

Part No.	Dim. A (Width)	Dim. B (Height)	Dim. C (Depth)	Dim. D (Inlets)	Dim. E
12200	12 1/4"	2 1/2"	3/4"	1 1/4"	8 3/4"
12213	9 1/8"	2 1/2"	3/4"	1 1/4"	5 7/8"



ENGINE ADAPTER QUICK REFERENCE

Year	Engine	Liters	Filter Thread Size	Filter O-ring Size	Engine Spin-on Adapter Type	Engine Sandwich Adapter Type
GM					Pg. 38, 39 & 41	Pg. 37 & 40
1963-2007	L/4,L/6,V-6,V-8	2.3, 3.8, 4.1, 4.3, 4.4, 5.0, 5.7, 6.5, 6.6, 7.4	13/16"-16	3 1/2"	J, L	A, F, C
1968-2008	L/4, L/6, V-6,V-8	2.4, 3.6, 3.8, 3.9, 4.2, 4.3, 4.6, 4.9, 5.0, 5.7, 6.6, 7.0, 7.5	13/16"-16	2 3/4"	J, L	A, B, F
1972-1985	L/4	1.8, 1.9	20 x 1.5mm	2 1/2"	J, M	D, M
1982-2007	L/4,V-6, V-8	2.2, 2.3, 2.5, 2.8, 3.1, 3.2, 3.3, 3.4, 3.5, 3.8, 4.1, 4.3	18 x 1.5mm	2 3/4"	J, N	A, B, D, H, N
2007-2008	V-8	5.3, 6.0, 6.2	22 x 1.5mm	2 3/4"	J, O	A, B, D, I, O
FORD						
1965-2007	L/4,L/6, V-6,V-8	2.0, 2.3, 2.5, 2.8, 2.9, 3.8, 3.9, 4.0, 4.2, 4.9, 4.7, 5.0, 5.8, 5.9, 6.4, 6.6, 7.5	3/4"-16	2 3/4"	E, J, K	A, B, D, E, K
1979-2008	V-6,V-8,V-10	4.0, 4.6, 5.0, 5.4, 5.8, 6.8	22 x 1.5mm	2 3/4"	J, O	A, B, D, I, O
1984-1987	L/4	2.0	20 x 1.5mm	2 3/4"	J, M	A, B, D, G, M
1991-1996	L/4	1.8, 2.0, 2.2	20 x 1.5mm	2 1/2"	J, M	D, M
DODGE / CHRYSLER						
1968-2000	L/4,L/6, V-6,V-8	1.6, 1.7, 2.0, 2.2, 2.4, 2.5, 2.8, 3.0, 3.2, 3.7, 3.8, 5.2, 5.6, 5.9, 6.3, 6.6, 7.0	3/4"-16	2 3/4"	E, J, K	A, B, D, E, K
1971-1990	L/4,V-6	1.5, 1.6, 1.8, 2.0, 2.2, 2.4, 2.5, 3.0	20 x 1.5mm	2 3/4"	J, M	A, B, D, G, M
1982-1989	L/4,V-6	1.5, 1.8, 3.0, 3.8	20 x 1.5mm	2 1/2"	J, M	D, M
JEEP						
1965-2007	L/4,L/6,V-6,V-8	3.7, 4.0, 4.7, 5.2, 5.9	3/4"-16	2 3/4"	E, J, K	A, B, D, E, K
1987-1990	L/4,L/6,V-8	2.5, 4.0, 4.2, 5.9	20 x 1.5mm	2 3/4"	J, M	A, B, D, G, M
HONDA / ACURA						
1979-2008	L4,L/5,V-6	1.6, 1.7, 1.8, 2.0, 2.1, 2.3, 2.4, 2.5, 2.6, 2.7, 3.0, 3.2, 3.5	20 x 1.5mm	2 1/2"	J, M	D, M
ISUZU						
1981-1987	L/4,L/6,V-8	1.8, 1.9, 2.3	20 x 1.5mm	2 3/4"	J, M	A, B, D, G, M
1985-2004	L/4,V-6	1.5, 1.6, 1.8, 1.9, 2.3, 3.2, 3.5	20 x 1.5mm	2 1/2"	J, M	D, M
1996-2003	L/4,V-6	2.2, 2.8, 3.1, 4.3	18 x 1.5mm	2 3/4"	J, N	A, B, D, H, N
MAZDA						
1978-2006	L/4,V-6	1.3, 1.5, 1.6, 1.8, 2.0, 2.2, 2.3, 2.5, 2.6, 3.0	20 x 1.5mm	2 1/2"	J, M	D, M
1991-2007	L/4,V-6	2.2, 2.3, 2.5, 3.0, 4.0	3/4"-16	2 3/4"	E, J, K	A, B, D, E, K
MITSUBISHI						
1985-2001	L/4	1.6, 1.8, 2.0, 2.4, 2.6	20 x 1.5mm	2 3/4"	J, M	A, B, D, G, M
1985-2008	L/4,V-6	1.5, 1.8, 2.0, 2.4,	20 x 1.5mm	2 1/2"	J, M	D, M
NISSAN						
1991-2008	L/4,V-6	1.8, 2.5, 3.0, 3.3, 3.5, 4.0, 5.6	20 x 1.5mm	2 1/2"	J, M	D, M
SUBARU						
1987-2008	L/3,H/4,H/6	1.2, 1.8, 2.2, 2.5, 3.0, 3.3, 3.6	20 x 1.5mm	2 1/2"	J, M	D, M
TOYOTA						
1975-2008	L/4,L/6, V-6,V-8	1.2, 1.3, 1.6, 1.8, 1.9, 2.0, 2.2, 2.4, 2.6, 2.7, 2.8, 3.0, 3.3, 3.4, 4.0, 4.2, 4.5, 4.7	3/4"-16	2 3/4"	E, J, K	A, B, D, E, K
1980-2008	L/4	1.5, 1.6, 1.8, 2.0, 2.2, 2.4	3/4"-16	2 1/2"	E, J, K	D, K
VW						
1978-2007	L/4,V-6	1.5, 1.6, 1.7, 1.8, 2.0, 2.2, 2.5	3/4"-16	2 3/4"	E, J, K	A, B, D, E, K

ENGINE OIL COOLER KITS

Engine Sandwich Adapter Kits

- Can reduce oil temperature up to 50° F
- Helps reduce coolant temperature
- Extends engine life
- Offered in 3 cooler styles to fit any application
- Complete hardware kit included



The bottom half of your engine relies entirely on the engine oil for cooling. Keeping the oil in the correct temperature range prolongs the life of the oil, helping to keep internal engine parts within the factory tolerances while extending the life of the engine.

See Engine Adapter Quick Reference Guide on page 36 for specific applications.

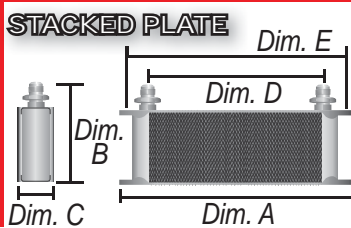
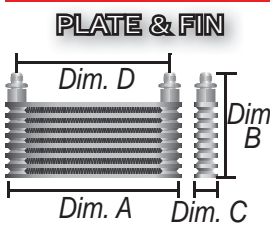
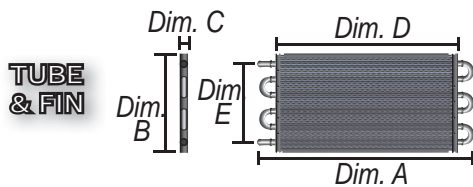
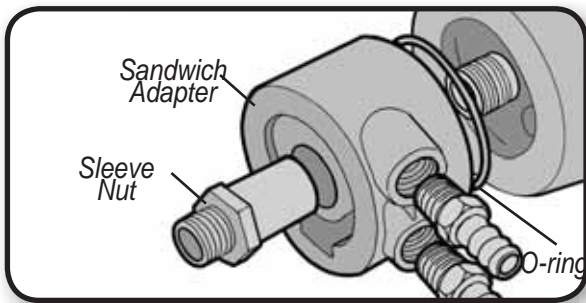

Part No.	Repl. Cooler	Application	COOLER DIMENSIONS				
			Dim. A	Dim. B	Dim. C	Dim. D	Dim. E
Tube & Fin							
15505	15302	Type A	16 5/8"	7 5/8"	3/4"	6 1/4"	13 3/4"
15502		Type B					
15503		Type C					
Plate & Fin							
15405	15851	Type A	9 7/8"	9 1/2"	1 1/4"	8 9/16"	----
Stacked Plate							
15605	51008	Type A	13"	4 9/16"	2"	11"	12 1/4"
15602		Type B					
15603		Type C					
15604		Type D					

For vehicle specific applications see application guide or visit www.derale.com

Engine Spin-On Adapter Kits

- Can reduce oil temperature up to 50° F
- Helps reduce coolant temperature
- Extends engine life
- Includes ports-up filter mount (Fram PH8A equivalent filters)
- Offered in 3 cooler styles to fit any application
- Complete hardware kit included

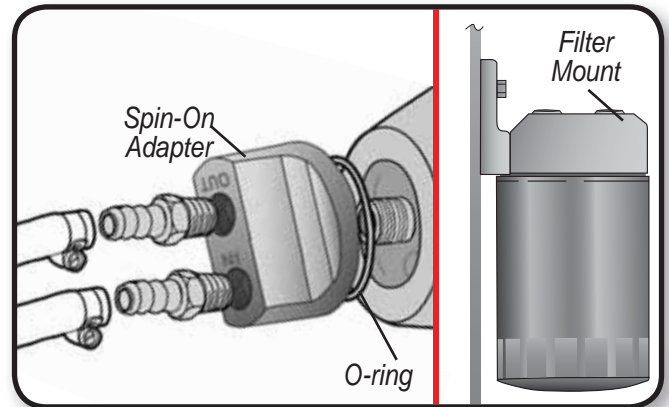
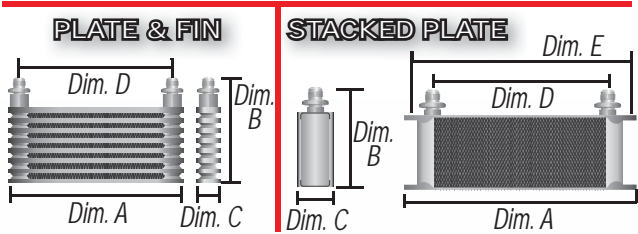
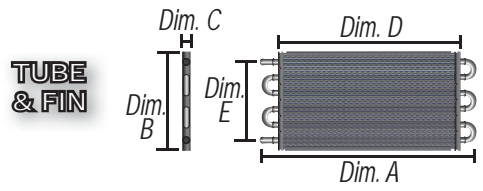

See Engine Oil Quick Reference Guide on page 36 for specific applications.

Part No.	Repl. Cooler	Application	COOLER DIMENSIONS				
			Dim. A	Dim. B	Dim. C	Dim. D	Dim. E
Tube & Fin							
15551	15302	Type J	16 5/8"	7 5/8"	3/4"	6 1/4"	13 7/8"
Plate & Fin							
15451	15851	Type J	9 7/8"	9 1/2"	1 1/4"	8 9/16"	----
Stacked Plate							
15651	51008	Type J	13"	4 9/16"	2"	11"	12 1/4"



For vehicle specific applications see application guide or visit www.derales.com



ENGINE OIL FILTER RELOCATION KITS

- Allows for oil filter to be moved to a more convenient location
- Faster and easier filter changes
- Ideal for engine swaps
- Increases oil capacity
- Available in single & dual filter mounts
- Cast from high quality aluminum
- 10 feet 1/2" OEM spec hose provided
- Filter mount uses Fram PH8A or equivalent
- Complete hardware kit included

See Engine Adapter Quick Reference Guide on page 36 for specific applications



Custom applications available

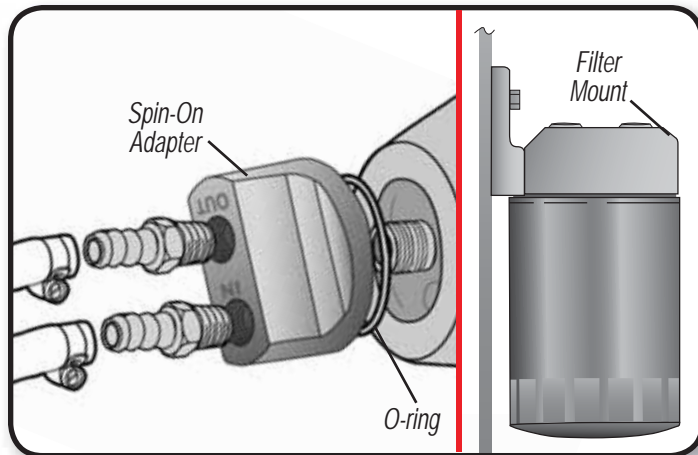

SINGLE MOUNT - PORTS UP



SINGLE MOUNT - PORTS UP UNIVERSAL



DUAL MOUNT - SIDE PORTS UNIVERSAL



Kit Part No.	Application	Engine Thread Size	Filter Thread Size	Filter Landing	Inlet/Outlet Ports
Single Mount - Ports Up					
15715	Type K	3/4"-16	3/4"-16	2 1/2", 2 3/4"	1/2" NPT
15716	Type L	13/16"-16	3/4"-16	2 1/2", 2 3/4", 3 1/2"	1/2" NPT
15717	Type N	18 x 1.5mm	3/4"-16	2 1/2", 2 3/4"	1/2" NPT
15718	Type M	20 x 1.5mm	3/4"-16	2 1/2", 2 3/4"	1/2" NPT
15725	Type O	22 x 1.5mm	3/4"-16	2 1/2", 2 3/4"	1/2" NPT
15748	Type J	3/4"-16, 13/16"-16, 18x1.5mm, 20x1.5mm, 22x1.5mm	3/4"-16	2 1/2", 2 3/4", 3 1/2"	1/2" NPT
Dual Mount - Side Ports					
15749	Type J	3/4"-16, 13/16"-16, 18x1.5mm, 20x1.5mm, 22x1.5mm	3/4"-16	2 1/2", 2 3/4", 3 1/2"	1/2" NPT

For vehicle specific applications see application guide or visit www.derale.com

ENGINE SANDWICH ADAPTER KITS

The purpose of a Sandwich Adapter is to provide external oil lines for oil coolers without relocating the factory oil filter.

- Cast from high quality aluminum
- Four designs to fit most applications
- Maintains factory equivalent oil filter



Custom applications available

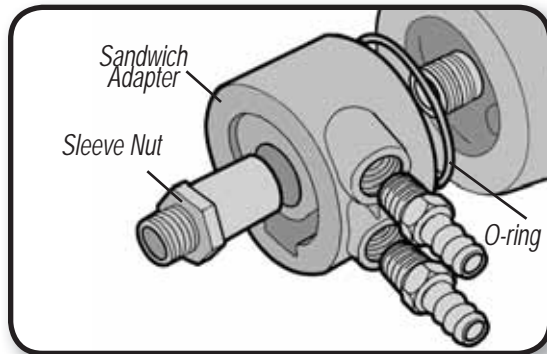

See Engine Adapter Quick Reference Guide on page 36 for specific applications

Kit Part No. - Includes sandwich adapter, sleeve nut(s) & O-ring(s)

Complete Kit Part No. - Includes brass fittings, sandwich adapter, sleeve nut(s) & O-ring(s)



Complete Kit Part No.	Kit Part No.	Application	Engine Thread Sizes	O-ring Dia.	Thickness	Ports
Thermostatic						
15702	25702	Type B	3/4"-16, 13/16"-16, 18x1.5mm,	2 3/4"	1 3/4"	3/8" NPT
15782	25782	Type A	20x1.5mm, 22x1.5mm	2 3/4", 3 1/2"	1 3/4" or 2 1/8"	3/8" NPT
15730	25730	Type E	3/4"-16	2 3/4"	1 3/4"	3/8" NPT
15731	25731	Type F	13/16"-16	2 3/4", 3 1/2"	1 3/4" or 2 1/8"	3/8" NPT
15732	25732	Type G	20 x 1.5mm	2 3/4"	1 3/4"	3/8" NPT
15733	25733	Type H	18 x 1.5mm	2 3/4"	1 3/4"	3/8" NPT
15734	25734	Type I	22 x 1.5mm	2 3/4"	1 3/4"	3/8" NPT
Thermostatic (GM Applications Only)						
15720	25720	Type C	13/16"-16	3 1/2"	2 1/4"	1/2" NPT
Non-Thermostatic						
15735	-----	Type D	3/4"-16, 13/16"-16, 18x1.5mm,	2 1/2", 2 3/4"	1 3/4"	1/2" NPT
-----	25770	Type K	3/4"-16	2 1/2", 2 3/4"	1"	3/8" NPT
-----	25771	Type L	13/16"-16	2 1/2", 2 3/4"	1"	3/8" NPT
-----	25772	Type M	20 x 1.5mm	2 1/2", 2 3/4"	1"	3/8" NPT
-----	25773	Type N	18 x 1.5mm	2 1/2", 2 3/4"	1"	3/8" NPT
-----	25774	Type O	22 x 1.5mm	2 1/2", 2 3/4"	1"	3/8" NPT
-----	25783	Type D	3/4"-16, 13/16"-16, 18x1.5mm,	2 1/2", 2 3/4"	1"	3/8" NPT
			20x1.5mm, 22x1.5mm			

For vehicle specific applications see application guide or visit www.derales.com

ENGINE SPIN-ON ADAPTER KITS

The purpose of a Spin-on Adapter is to provide external oil lines for remote filter mounts and oil coolers.

See Engine Adapter Quick Reference Guide on page 36 for specific applications



Custom applications available

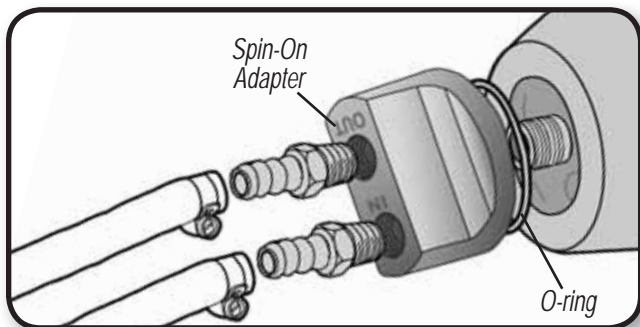

DUAL SIDE PORTS



Part No.	Application	Thread Size	O-ring Dia.	Ports
15746	Type K	3/4"-16	2 1/2", 2 3/4"	1/2" NPT

STANDARD SERIES

- Ultra bright finish
- New Billet style design
- Available in 6 numbers to fit all applications
- 1/2" NPT ports



PREMIUM SERIES

- Black powdercoated finish
- New Billet style design
- Available in 6 numbers to fit all applications
- -10 AN / 7/8"-14 O-ring ports



Standard Series Part No.	Ports	Premium Series Part No.	Ports	Application	Engine Thread Sizes	O-ring Dia.
15747	1/2" NPT	35747	-10 AN O-ring	Type J	3/4"-16, 13/16"-16, 18x1.5mm, 20x1.5mm, 22x1.5mm	2 1/2", 2 3/4", 3 1/2"
15703	1/2" NPT	35703	-10 AN O-ring	Type K	3/4"-16	2 1/2", 2 3/4"
15704	1/2" NPT	35704	-10 AN O-ring	Type N	18 x 1.5mm	2 1/2", 2 3/4"
15705	1/2" NPT	35705	-10 AN O-ring	Type L	13/16"-16	2 1/2", 2 3/4", 3 1/2"
15706	1/2" NPT	35706	-10 AN O-ring	Type M	20 x 1.5mm	2 1/2", 2 3/4"
15724	1/2" NPT	35724	-10 AN O-ring	Type O	22 x 1.5mm	2 1/2", 2 3/4"

For vehicle specific applications see application guide or visit www.derale.com

Filter Mounts - Standard Series

- Allows oil filter to be remote mounted anywhere
- Available in single or dual filter configurations
- Offered with or without hardware kit
- Cast from high quality aluminum
- 3 bolt heavy duty mounting plate

Individual fittings and accessories available on pages 46

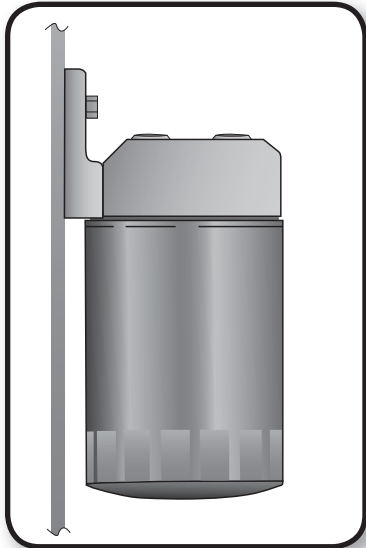

Single Mount - Ports Up



Kit Part No.	Mount Part No.	Filter Threads	Inlet/Outlet Ports
13005	25005	3/4"-16	3/8" NPT
15708	25708	3/4"-16	1/2" NPT
15728	25728	13/16"-16	1/2" NPT

Single Mount - Side Ports



Kit Part No.	Mount Part No.	Filter Threads	Inlet/Outlet Ports
15709	25709	3/4"-16	1/2" NPT

Dual Mount - Side Ports



Kit Part No.	Mount Part No.	Filter Threads	Inlet/Outlet Ports
15707	25707	3/4"-16	1/2" NPT

Single Mounts - Left or Right



Mount Part No.	Ports	Filter Threads	Inlet/Outlet Ports
25750	Left	3/4"-16	3/8" NPT
25751	Right	3/4"-16	3/8" NPT

REMOTE FILTER MOUNTS

Filter Mounts - Premium Series

- Allows oil filter to be remote mounted anywhere
- New innovative 180° double mount design
- Removable 3 hole mounting bracket
- Black powdercoated finish
- -10 AN / 7/8"-14 O-ring ports

Individual fittings and accessories available on pages 46

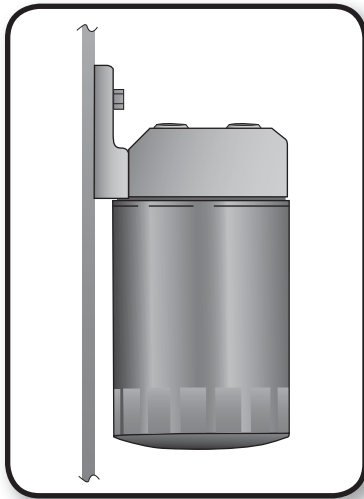

Single Mount - Ports Up



Mount Part No.	Filter Threads	Inlet/Outlet Ports
35708	3/4"-16	-10 AN / 7/8"-14 O-ring
35728	13/16"-16	-10 AN / 7/8"-14 O-ring
35784	Mounting Bracket Kit	

Dual Mount - Side Ports

- Absolute dual filtration system
- New design allows multiple filters to be mounted inline

Single Mount - Side Ports



Mount Part No.	Filter Threads	Inlet/Outlet Ports
35709	3/4"-16	-10 AN / 7/8"-14 O-ring
35729	13/16"-16	-10 AN / 7/8"-14 O-ring
35784	Mounting Bracket Kit	



Mount Part No.	Filter Threads	Inlet/Outlet Ports
35707	3/4"-16	-10 AN / 7/8"-14 O-ring
35727	13/16"-16	-10 AN / 7/8"-14 O-ring
35799	10 AN x 10 AN Aluminum coupler Fitting	

FLUID CONTROL THERMOSTATS

- Bypasses cooler at 180° F
- Provides quicker warm-up temps
- Perfect for cold weather climates
- Can be rotated 180° to switch flow direction
- Flows up to 20 gallons per minute
- Rated up to 200 PSI

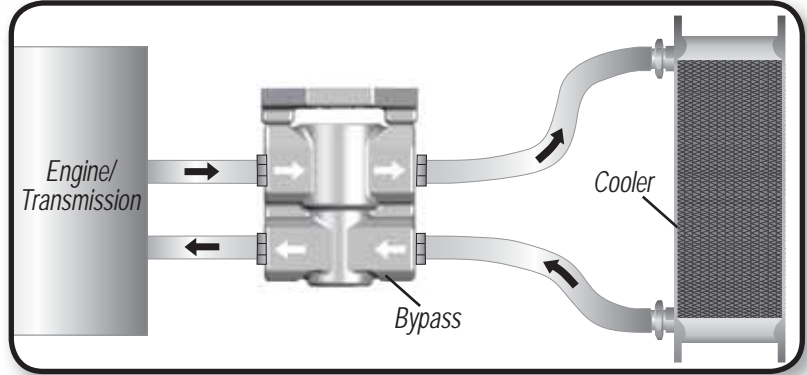

Recommended for:
 Transmissions
 Engines



Individual fittings and accessories available on pages 46

As the fluid temperatures exceed 180°F the thermostatic valve closes, allowing 95% flow through the oil cooler. At temps. below 180°F the valve is open, with 90% of the oil bypassing the cooler. The remaining 10% of the oil flows through the cooler, maintaining constant system pressure, preventing air pockets and eliminating cold oil shock.

Standard Series

- Ultra bright finish
- New Billet style design
- Kit Part No. - Includes brass fittings & hose clamps
- Available in 3/8" NPT or 1/2" NPT ports



Kit Part No.	Part No.	Description	Inlet/Outlet Ports
13011	25011	Thermostat only	3/8" NPT
15719	25719	Thermostat only	1/2" NPT
-----	25791	Thermostat w/Bracket	3/8" NPT
-----	25792	Thermostat w/Bracket	1/2" NPT
-----	25793	Bracket kit only	-----

Premium Series

- Black powdercoated finish
- New Billet style design
- -10 AN / 7/8"-14 O-ring ports



Part No.	Description	Inlet/Outlet Ports
35719	Thermostat only	-10 AN / 7/8"-14 O-ring
35782	Thermostat w/Bracket	-10 AN / 7/8"-14 O-ring
35783	Bracket kit only	-----

REMOTE FILTER KITS

Transmission Filter Kits

- Extends life of transmission
- Filters out contaminants more efficiently than OE screen type filters
- Universal - fits all automatic transmissions
- Increases fluid capacity

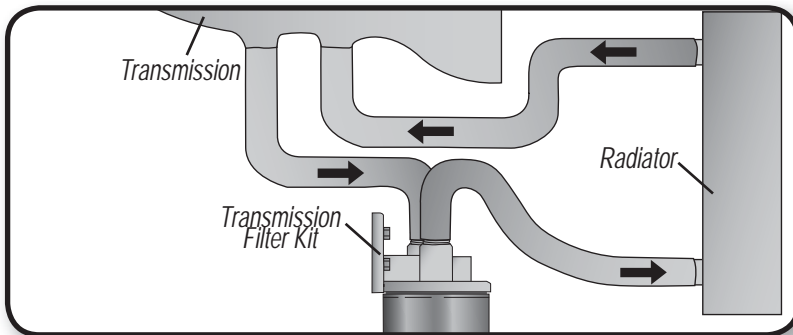

Part No.	Description	Filter Dimensions
13090	Standard kit - Includes all mounting hardware	3 1/2" O.D. x 3 1/8"
13091	Premium Kit - Includes all mounting hardware plus premium gauge kit	3 1/2" O.D. x 3 1/8"
13092	Replacement Filter	3 1/2" O.D. x 3 1/8"

Fuel Filter / Water Separator Kits

- Extends carburetor/fuel injector life
- Designed for all fuel types
- Improves engine performance
- Petcock allows for convenient draining of water

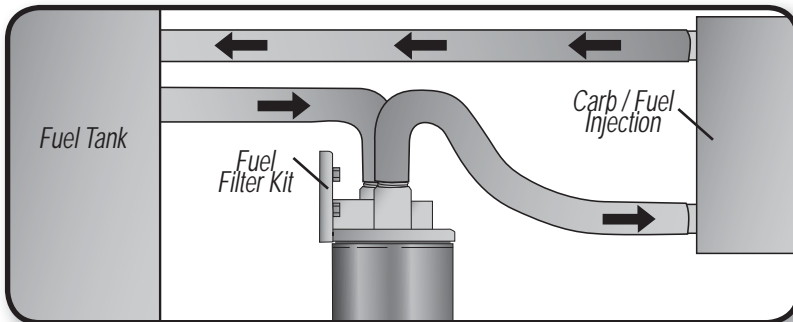

Part No.	Description	Filter Dimensions
13070	Single Mount - Side Ports	3 1/2" O.D. x 7 5/8"
13072	Single Mount - Ports Up	3 1/2" O.D. x 7 5/8"
13075	Replacement Filter	3 1/2" O.D. x 7 5/8"

FITTINGS & ACCESSORIES

STRAIGHT HOSE BARB FITTINGS

Part No.	Description	U/M
98100	1/4" NPT Male x 3/8" Barb	Ea.
98101	3/8" NPT Male x 3/8" Barb	Ea.
98102	3/8" NPT Male x 1/2" Barb	Ea.
98103	1/2" NPT Male x 1/2" Barb	Ea.
98104	1/4" Female x 3/8" Barb	Ea.
98105	3/8" Female x 3/8" Barb	Ea.
98106	1/2" Female x 1/2" Barb	Ea.



AN ALUMINUM ADAPTER FITTINGS

Part No.	Description	U/M
59106	-6 AN x 5/8"-18 O-ring	Ea.
59108	-8 AN x 5/8"-18 O-ring	Ea.
59006	-6 AN x -10 AN O-ring	Ea.
59008	-8 AN x -10 AN O-ring	Ea.
59010	-10 AN x -10 AN O-ring	Ea.
59012	-12 AN x -10 AN O-ring	Ea.



AN SWIVEL HOSE BARB FITTINGS

Part No.	Description	U/M
98200	-6 AN Female x 3/8" Barb	Ea.
98201	-8 AN Female x 3/8" Barb	Ea.
98202	-8 AN Female x 1/2" Barb	Ea.
98203	-10 AN Female x 1/2" Barb	Ea.



-10 AN ALUMINUM COUPLER FITTING

Part No.	Description	U/M
35799	-10 AN O-ring x -10 AN O-ring	Ea.



AN HOSE BARB FITTINGS

Part No.	Description	U/M
98204	-6 AN Male x 3/8" Barb	Ea.
98205	-8 AN Male x 1/2" Barb	Ea.



PLUGS

Part No.	Description	U/M
98400	1/2" NPT - Steel	Ea.
35798	-10 AN O-ring - Aluminum	Ea.



REDUCER BUSHINGS

Part No.	Description	U/M
98450	3/8" Male x 1/8" Female	Ea.
98451	1/2" Male x 1/8" Female	Ea.
98452	1/2" Male x 3/8" Female	Ea.



AN ALUMINUM SWIVEL FITTINGS WITH 1/8" NPT SIDE PORT

Part No.	Description	U/M
35920	-6 AN Male x -6 AN Female	Ea.
35921	-8 AN Male x -8 AN Female	Ea.
35922	-10 AN Male x -10 AN Female	Ea.



TEFLON TAPE

Part No.	Description	U/M
15714	1/2" x 43 Ft.	Ea.



FILTER NIPPLES

Part No.	Description	U/M
98020	3/4"-16	Ea.
98021	13/16"-16	Ea.



BELT DRIVEN FAN SPACERS

The Leader in Performance Cooling

- Aluminum construction
- Clear Anodized finish
- Multiple sizes for all applications

Our extruded aluminum fan spacers are available in a variety of sizes and come with a clear anodized finish. Mounting hardware included.

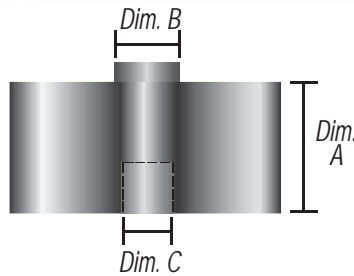

Warning: Fan should have a minimum clearance of 3/4" from the radiator, belts, hoses or pulleys.

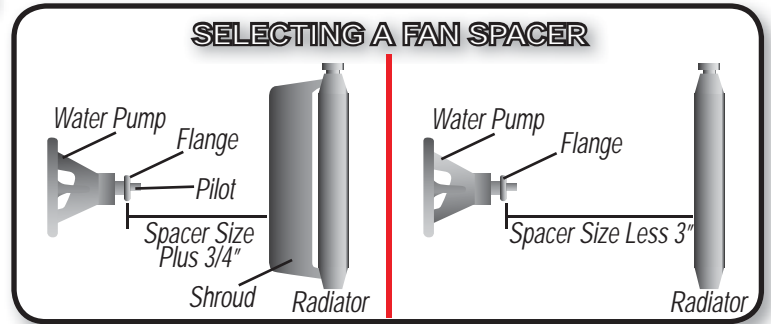

Part No.	Dim. A (Length)	Dim. B (Male Pilot Diameter)	Dim. C (Female Pilot Diameter)	Bolts (4 each)	Flange
31500	1/2"	5/8"	5/8"	5/16-18 / 5/16-24	1 3/4"-2 1/4"
31510	1"	5/8"	5/8"	5/16-18 / 5/16-24	1 3/4"-2 1/4"
31515	1 1/2"	5/8"	5/8"	5/16-18 / 5/16-24	1 3/4"-2 1/4"
31518	1 3/4"	5/8"	5/8"	5/16-18 / 5/16-24	1 3/4"-2 1/4"
31520	2"	5/8"	5/8"	5/16-18 / 5/16-24	1 3/4"-2 1/4"
31521	2"	5/8"	5/8"	8mm x 1.25	1 3/4"-2 1/4"
31522	2"	5/8"	5/8"	6mm x 1.00	1 3/4"-2 1/4"
31531	2"	5/8"	3/4"	8mm x 1.25	1 3/4"-2 1/4"
31530	2"	5/8"	3/4"	5/16-18 / 5/16-24	1 3/4"-2 1/4"
31540	2 1/4"	5/8"	5/8"	5/16-18 / 5/16-24	1 3/4"-2 1/4"
31541	2 1/4"	5/8"	1.180	8mm x 1.25	1 3/4"-2 1/4"
31546	2 1/4"	5/8"	5/8" or 3/4"	8mm x 1.25	1 3/4"-2 1/4"
31547	2 1/4"	5/8"	5/8" or 3/4"	6mm x 1.00 / 8mm x 1.25	1 3/4"-2 1/4"
31551	3 1/2"	5/8"	1.180	8mm x 1.25	1 3/4"-2 1/4"
34510	1"	5/8"	5/8" or 3/4"	5/16-18 / 5/16-24	1 3/4"-2 1/4"
34515	1 1/2"	5/8"	5/8" or 3/4"	5/16-18 / 5/16-24	1 3/4"-2 1/4"
34520	2"	5/8"	5/8" or 3/4"	5/16-18 / 5/16-24	1 3/4"-2 1/4"
34540	2 1/4"	5/8"	5/8" or 3/4"	5/16-18 / 5/16-24	1 3/4"-2 1/4"

Heavy Duty Flex Fans

- Improves performance and mileage
- Heavy duty steel hubs
- Durable stainless steel blades
- Available in standard or reverse rotation
- Rated up to 10,000 RPM
- Large surface area pulls more air at low speeds
- Reinforced blade construction extends fan life

Derale Heavy Duty Flex Fans provide maximum airflow at low RPMs when the vehicle speed provides little or no airflow through the radiator. At higher RPMs, the vehicle speed provides ample airflow and the fan blades flatten out to minimize engine loading, increasing horsepower and mileage. Fan spacer sold separately.

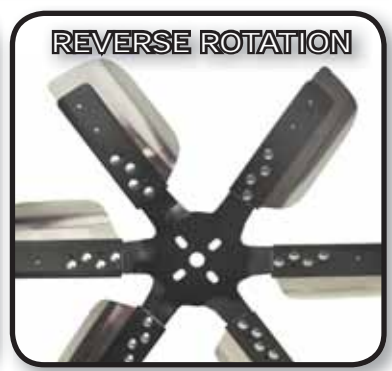
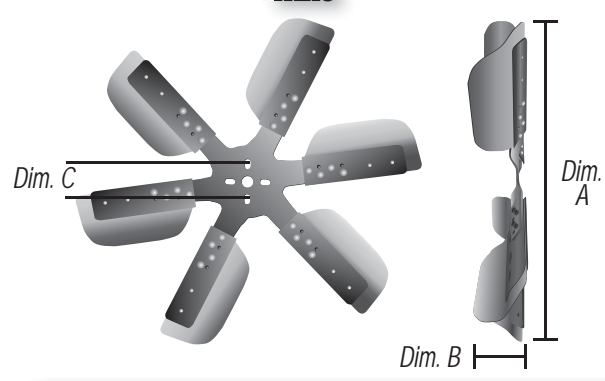

Stainless Black Hub Part No.	Stainless Chrome Hub Part No.	Fan Size	Rotation	Dim. A (Diameter)	Dim. B (Depth)	Dim. C (Flange)
17013	17213	13"	Standard	13"	2 1/8"	1 3/4"-2 1/4"
17015	17215	15"	Standard	14 3/4"	2 3/4"	1 3/4"-2 1/4"
17017	17217	17"	Standard	17 1/4"	2 3/8"	1 3/4"-2 1/4"
17018	17218	18"	Standard	18 1/4"	2 3/8"	1 3/4"-2 1/4"
17019	17219	19"	Standard	19 1/4"	2 3/8"	1 3/4"-2 1/4"
17617	17817	17"	Reverse	17 1/4"	2 3/8"	1 3/4"-2 1/4"
17618	17818	18"	Reverse	18 1/4"	2 3/8"	1 3/4"-2 1/4"
17619	17819	19"	Reverse	19 1/4"	2 3/8"	1 3/4"-2 1/4"

BELT DRIVEN FANS

High Performance Stainless

- Stainless steel fan blades
- Chrome plated or black powdercoated hub
- Rated up to 8,000 RPM's
- Standard or reverse rotation

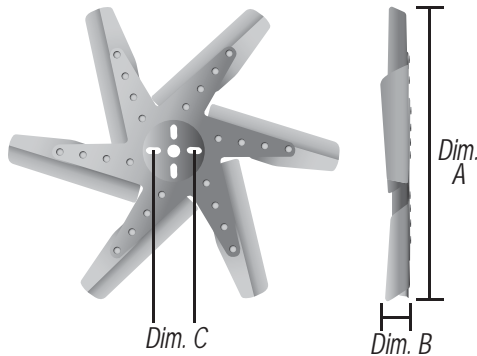

Stainless Black Hub Part No.	Stainless Chrome Hub Part No.	Fan Size	Rotation	Dim. A (Diameter)	Dim. B (Depth)	Dim. C (Flange)
19113	19213	13"	Standard	13 3/8"	1 1/8"	1 3/4"-2 1/4"
19115	19215	15"	Standard	15 1/4"	1 1/8"	1 3/4"-2 1/4"
19117	19217	17"	Standard	17"	1 1/8"	1 3/4"-2 1/4"
19118	19218	18"	Standard	18 1/4"	1 1/8"	1 3/4"-2 1/4"
19313	19713	13"	Reverse	13 3/8"	1 1/8"	1 3/4"-2 1/4"
19315	19715	15"	Reverse	15 1/4"	1 1/8"	1 3/4"-2 1/4"
19317	19717	17"	Reverse	17"	1 1/8"	1 3/4"-2 1/4"
19318	19718	18"	Reverse	18 1/4"	1 1/8"	1 3/4"-2 1/4"

High Performance Aluminum

- Aluminum fan blades
- Chrome plated hubs
- Rated up to 8,000 RPM's
- Red or blue anodized fan blades

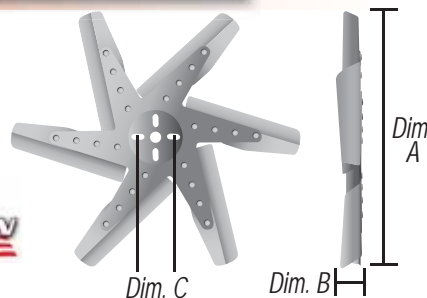

Part No.	Fan Size	Rotation	Blade Color	Dim. A (Diameter)	Dim. B (Depth)	Dim. C (Flange)
19417	17"	Standard	Red	17"	1 1/8"	1 3/4"-2 1/4"
19418	18"	Standard	Red	18 1/4"	1 1/8"	1 3/4"-2 1/4"
19517	17"	Standard	Blue	17"	1 1/8"	1 3/4"-2 1/4"
19518	18"	Standard	Blue	18 1/4"	1 1/8"	1 3/4"-2 1/4"

BELT DRIVEN FANS

High Performance Aluminum

- Aluminum fan blades
- Black powdercoated hub
- Rated up to 8,000 RPM's
- Red or blue anodized fan blades

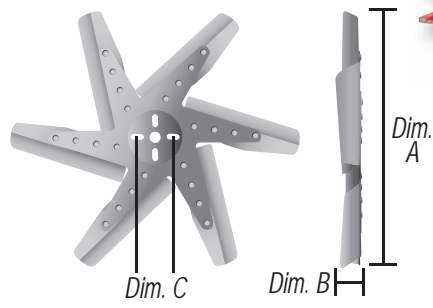

Part No.	Fan Size	Rotation	Blade Color	Dim. A (Diameter)	Dim. B (Depth)	Dim. C (Flange)
19817	17"	Standard	Red	17"	1 1/8"	1 3/4"-2 1/4"
19818	18"	Standard	Red	18 1/4"	1 1/8"	1 3/4"-2 1/4"
19917	17"	Standard	Blue	17"	1 1/8"	1 3/4"-2 1/4"
19918	18"	Standard	Blue	18 1/4"	1 1/8"	1 3/4"-2 1/4"

Fan Clutch Fans

- Steel fan blades
- Maximum full-time airflow
- Black powdercoated finish
- Standard and reverse rotation

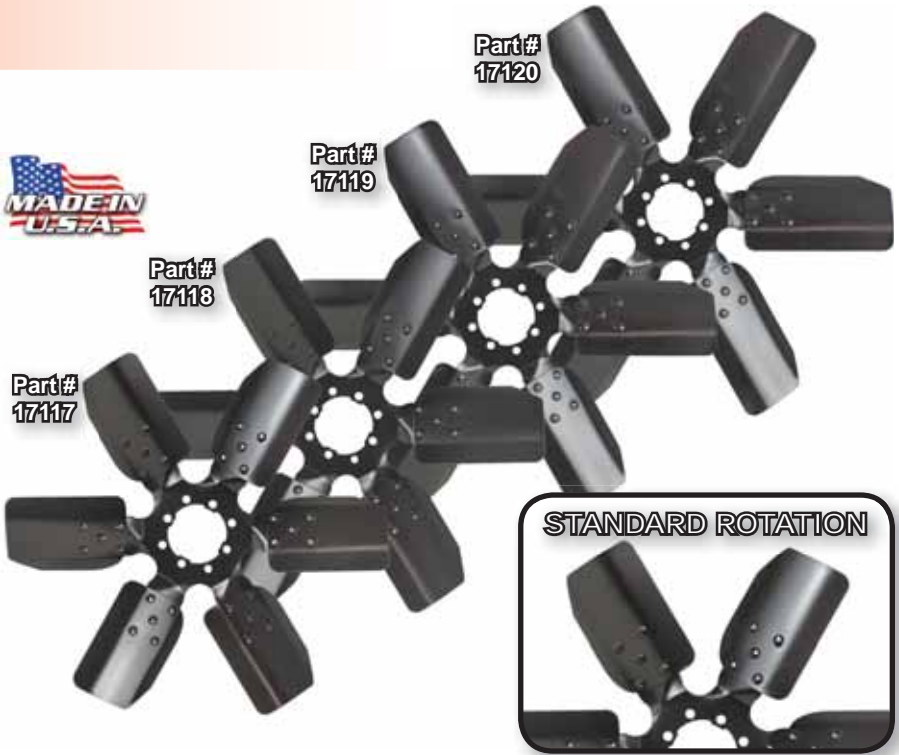
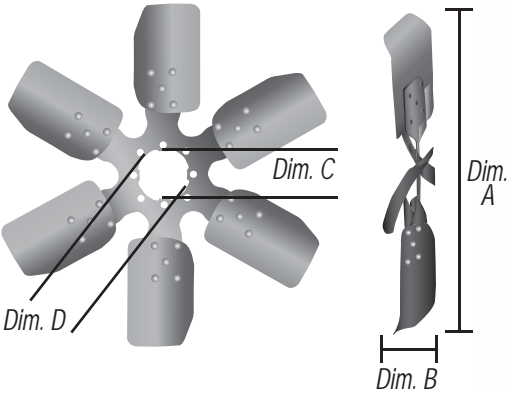

Standard Rotation Part No.	Reverse Rotation Part No.	Fan Size	Dim. A (Diameter)	Dim. B (Depth)	Dim. C (Flange)	Dim. D (Flange)
17117	17917	17"	17 1/4"	2"	2 3/8"	2 19/32"
17118	17918	18"	18"	2"	2 3/8"	2 19/32"
17119	17919	19"	19 1/8"	2"	2 3/8"	2 19/32"
17120	17920	20"	20"	2"	2 3/8"	2 19/32"

BELT DRIVEN FANS

Rigid Race Steel Blade Fans

- Steel fan blades
- Maximum full-time airflow
- Rated up to 8,000 RPM's
- Standard and reverse rotation

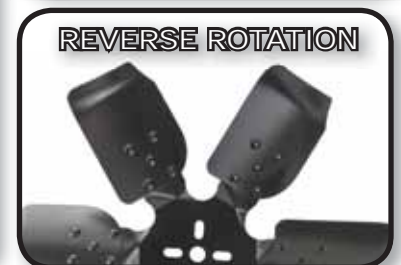
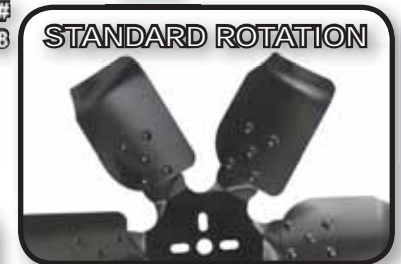
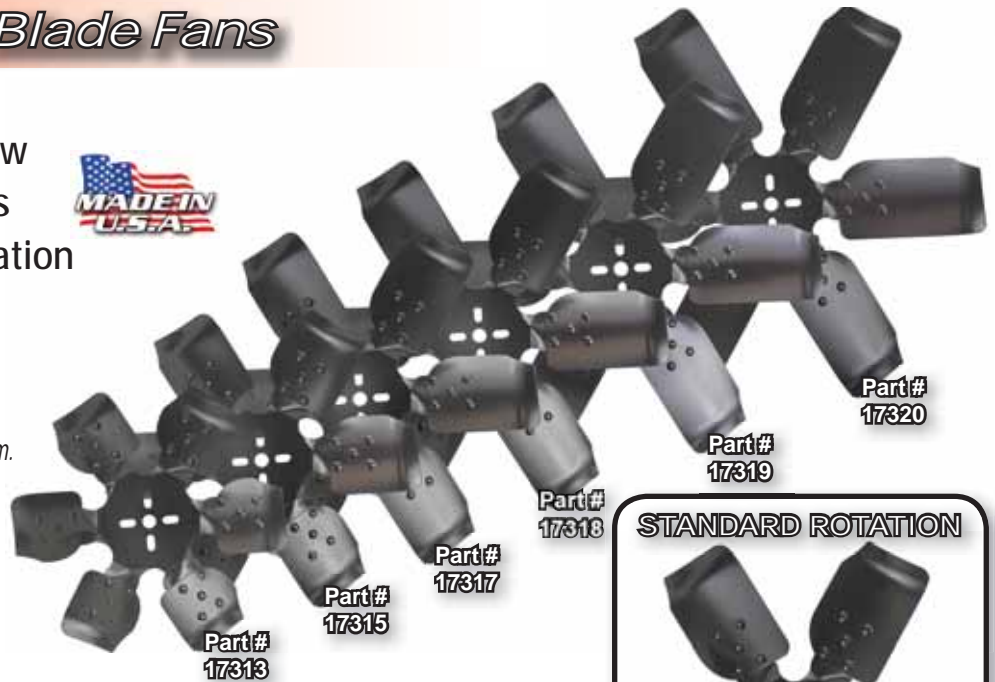
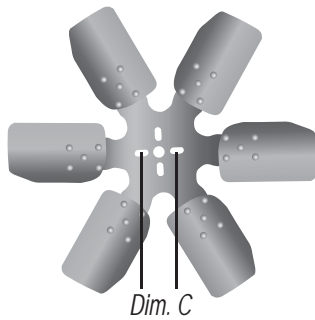

Standard Rotation Part No.	Reverse Rotation Part No.	Fan Size	Dim. A (Diameter)	Dim. B (Depth)	Dim. C (Flange)
17313	17413	13"	13"	2 3/16"	1 3/4"-2 1/4"
17315	17415	15"	15"	2 7/16"	1 3/4"-2 1/4"
17317	17417	17"	17"	2 5/16"	1 3/4"-2 1/4"
17318	17418	18"	18"	2 1/4"	1 3/4"-2 1/4"
17319	17419	19"	19"	2 1/4"	1 3/4"-2 1/4"
17320	17420	20"	19 7/8"	2 1/4"	1 3/4"-2 1/4"

Rigid Race Aluminum Blade Fans

- Aluminum fan blades
- Perfect replacement for fan clutch and fan
- Maximum full-time airflow
- Rated up to 8,000 RPM's

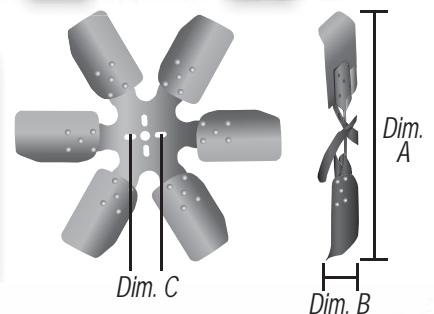

Part No.	Fan Size	Rotation	Dim. A (Diameter)	Dim. B (Depth)	Dim. C (Flange)
17513	13"	Standard	12 3/4"	2"	1 3/4"-2 1/4"
17515	15"	Standard	14 3/4"	2"	1 3/4"-2 1/4"
17517	17"	Standard	16 3/4"	2"	1 3/4"-2 1/4"
17518	18"	Standard	17 3/4"	2"	1 3/4"-2 1/4"

FAN CLUTCHES

- All aluminum body for maximum heat dissipation
- High quality heavy-duty bearing with Hi-Temp moly grease
- Multi-Fin design grabs more air and dispels more heat
- CNC machined to OE Specifications

For vehicle specific applications see application guide or visit www.derales.com
Applications available to fit most year, make and model vehicles



Fan clutches are engineered to improve the vehicle's cooling system efficiency. The clutch engages the fan at low speeds when additional cooling is needed. At high speeds the clutch disengages the fan, removing the load against the engine and allowing the engine to run more efficiently.

There are two types of fan clutches, non-thermal and thermal. Non-thermal fan clutches engage the fan based on the shaft speed of the water pump. Thermal fan clutches engage the fan based on a bi-metal thermostatic coil, which senses the under hood temperature.

Derales offers a full line of thermal and non-thermal fan clutches to fit most popular foreign and domestic applications. Fan clutches are available in standard and reverse rotation.

NON-THERMAL



THERMAL



THERMAL SCREW ON



THERMAL IMPORT



HEAVY DUTY THERMAL



THERMAL TRUCK DRIVE





In Memory of
Pete Riker

11/15/1944 - 7/30/2008

Pete was old school when it came to lending a helping hand, but innovative and forward thinking with his engineering, knowledge and abilities. He will be sorely missed by family, friends, and all those in the hot rodding community who knew him.

Rest in peace, Pete.



DERALE
PROVEN IN
ALL ALTITUDES!



WWW.DERALE.COM



DISTRIBUTED BY:



DERALE
PERFORMANCE

The Leader in Performance Cooling

800-421-6288 • 323-266-3850 • Fax 323-263-3948
3901 Medford Street, Los Angeles, CA 90063

\$3.00